

## LIMIT ADJUSTMENT SCREWS ON OPPOSITE SIDE FROM MOTOR CABLE

MATERIAL ROLLS DOWN ON SAME SIDE AS LIMITS

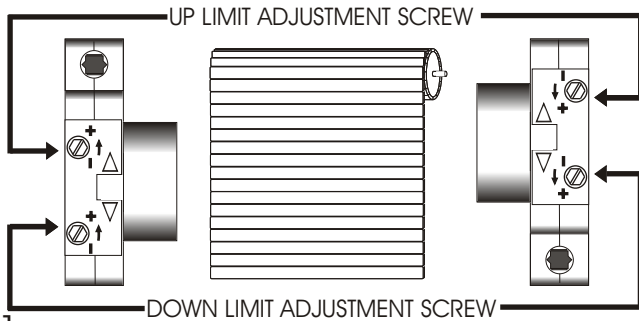

1

MATERIAL ROLLS DOWN ON OPPOSITE SIDE FROM LIMITS

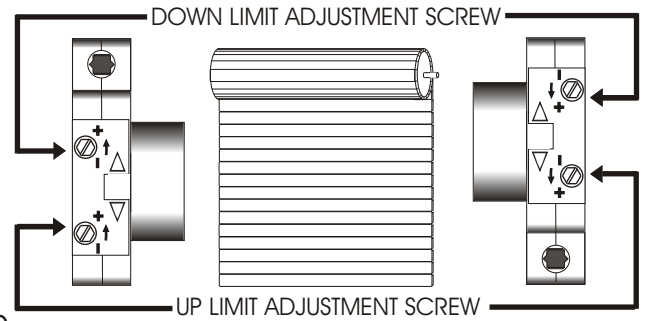

2

## LIMIT ADJUSTMENT SCREWS ON SAME SIDE AS MOTOR CABLE

MATERIAL ROLLS DOWN ON SAME SIDE AS LIMITS

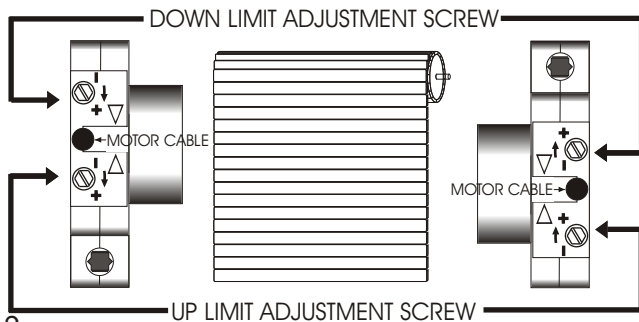

3

MATERIAL ROLLS DOWN ON OPPOSITE SIDE FROM LIMITS

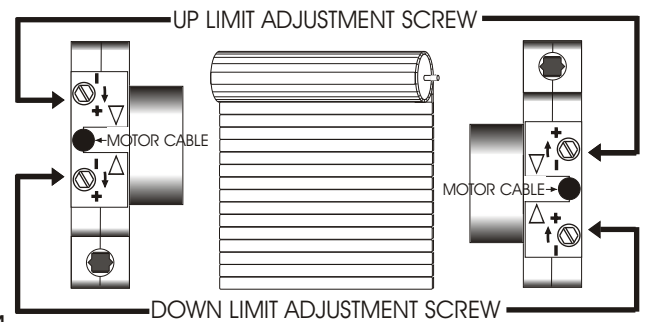

4

1) Identify which limit adjustment screw controls the up limit and which controls the down limit (see above diagrams). It is important to note that the large triangular arrows by the limit adjustment screw refer to the tube's rotation that limit controls. Thus if the material comes off the tube on the back side and you are adjusting the limits from the side that the motor cable is not on (as per diagram 2), the limit adjustment screw with the arrow facing up controls the down limit and vice versa.

2) Turning an adjustment screw positive (+) will increase the maximum travel in the direction that it controls, and turning it negative (-) will decrease the maximum travel. **For the adjustment screws on the side without the motor cable**, turning clockwise is negative (-) and counterclockwise is positive (+). **For the adjustment screws on the side with the motor cable**, turning clockwise is positive (+) and counterclockwise is negative (-)

3) To set a limit, run the motor in the selected direction.

4) If the motor stops on its own before reaching the desired stop, turn the appropriate limit screw positive. Every 2 to 3 turns of the limit adjustment screw will allow the motor to travel about 1 inch further. After every few turns of the limit adjustment screw, use the control switch to move the motor to the new limit position. (If the motor does not stop on its own before reaching the desired limit, go to step 6)

5) When you are approximately at the desired limit position, use the control switch to run the motor away from the limit 2 to 3 feet, and then back. This will allow you to see precisely where the limit is set. Make small adjustments and repeat.

6) If the motor does not stop on its own at least 6 inches before the desired limit position, stop the motor with the control switch. Then turn the limit adjustment screw in the negative direction. Confirm that the motor is stopped at the limit and set the limit as per steps 4 and 5. If the motor is not stopped at the limit, continue turning the limit adjustment screw (up to 120 turns may be required)

NOTE: The motor has a built in thermal cutoff. If after several minutes of use the motor will not run in either direction, allow the motor to cool for approximately 20 minutes.