

Model: NOMO & RIALTO Fabric Roof Bioclimatic Pergola®



Application	Maximum Width	Maximum Projection	Options
Free Standing or Wall Mounted Commercial & Residential	5.5 m / 18 ft. wide per module	7 m / 22' 11" proj.	Undercover, LEDS, Heaters, Side Screens Set Flooring

PRODUCT FEATURES:

- Retractable fabric roof pergola.
- Ideal for free standing or wall mounted applications or where flat installations are required.
- Integrated gutter and downspouts for water drainage.
- Arched fabric for better water management.
- Multiple modules can be mounted side by side with common posts to create larger width.
- All aluminum frame powder coated
- Motorized all sizes.
- Screens optional on NOMO model only.
- Ideal for adding roll down zipper screens. to create an enclosed space.
- Powered with a Somfy Motor.

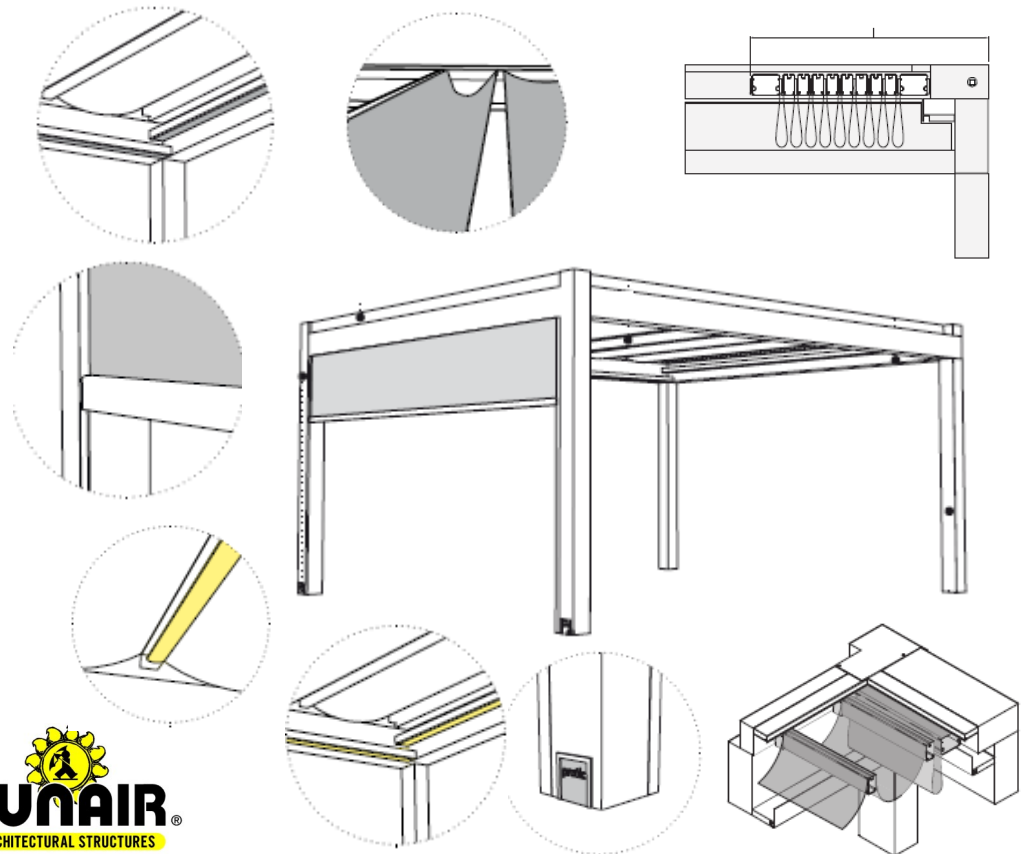

FUNDAMENTALS: NOMO & RIALTO

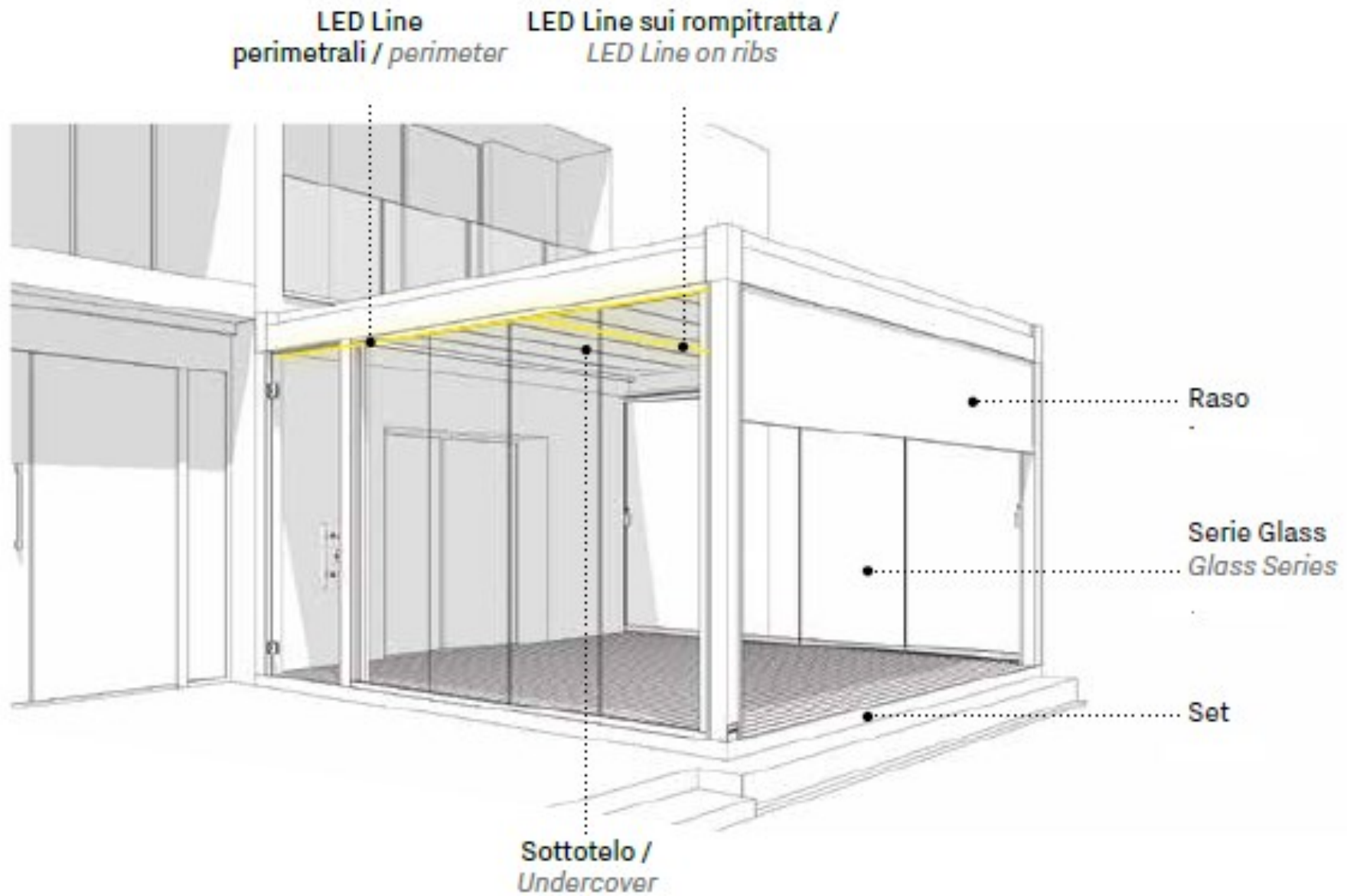

NOMO & RIALTO: Commercial Installations



NOMO & RIALTO: Residential Installations



NOMO & RIALTO ADVANTAGES

The rounded arched fabric allows for a compact structure design. The supporting profile and guides are 12 ½” high (32 cm).

Tilting gutter is a Pratic patent managing water discharge within the structure. Optional telescoping post feet are available for ease of installation.

For greater perimeter protection, the NOMO model can be configured with retractable RASO zipper screens within the structural elements.



The NOMO & RIALTO offers more pre-assembled structure components for a safer an easier installation on site.

The NOMO & RIALTO RGB LED multi colored lighting offers a fascinating elegant remote controlled lighting option (White lights included).

NOMO & RIALTO is a solid made to measure structure that can reach large sizes (18' x 22' 11"). Coupling of multiple structures is possible with minimal intermediate posts.

NOMO & RIALTO: Some possible model configurations



More configurations

C STRUCTURES JOINED ALONG DEPTH SIDE P WITH DIFFERENT WIDTHS

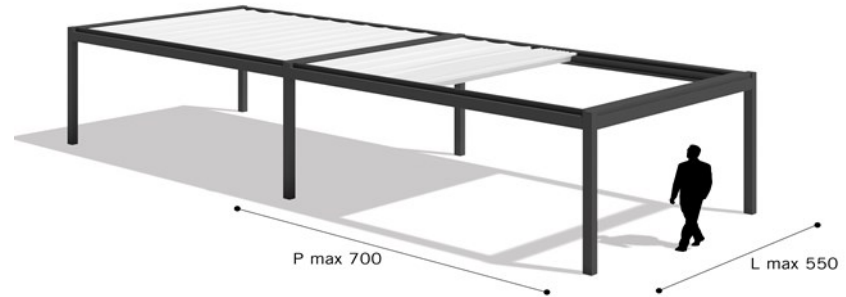

RASO SCREENS NOMO ONLY

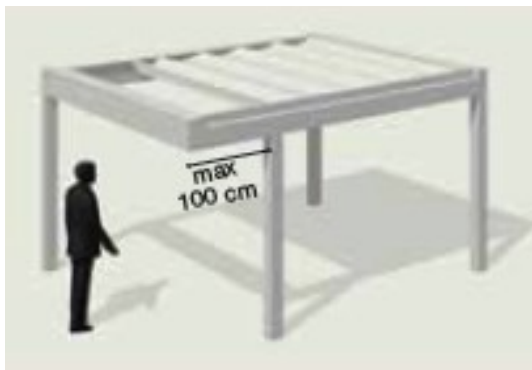

Cantilevered post maximum 100 cm or 39" from corner.

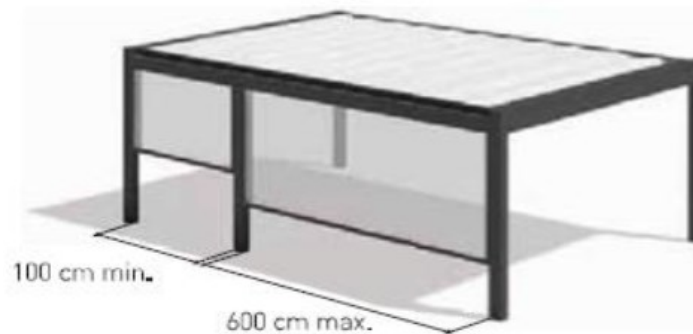

Out of standard configurations



Inquire with Sunair® office on any system that pairs modules on both the (L) width side and (P) projection side simultaneously at the same time.

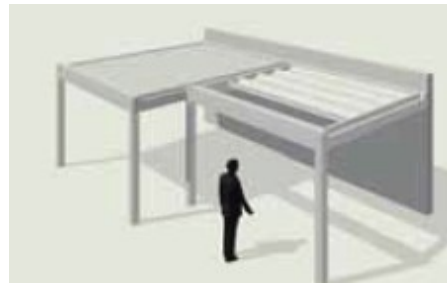

Inquire with Sunair office on this possibility eliminating center post at front

Available with max width 6 meters x 4 meters projection (19' 8" Wide x 13' 1 1/2" Projection). Optional cantilevered posts not available in this configuration.



Rialto unit mounted wall to wall. Available with Rialto single module only. Max size in this configuration is 5.5 meters x 7 meters projection (approx.: 18' w x 22' 11" proj.) Please inquire with Sunair on exact size available. NOTE: Customer has to add their own discharge water tray and down spout for water management.



Also inquire on uneven sections or modules to be joined.



NOMO

01L : Free standing and if multiple Coupled on projection side.

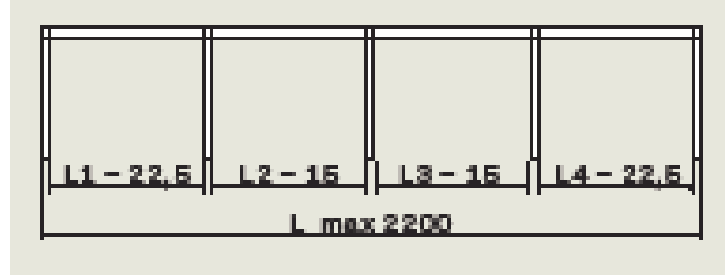
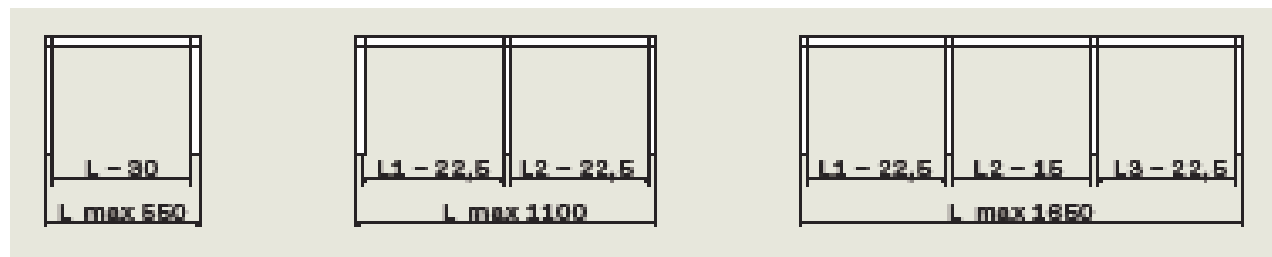
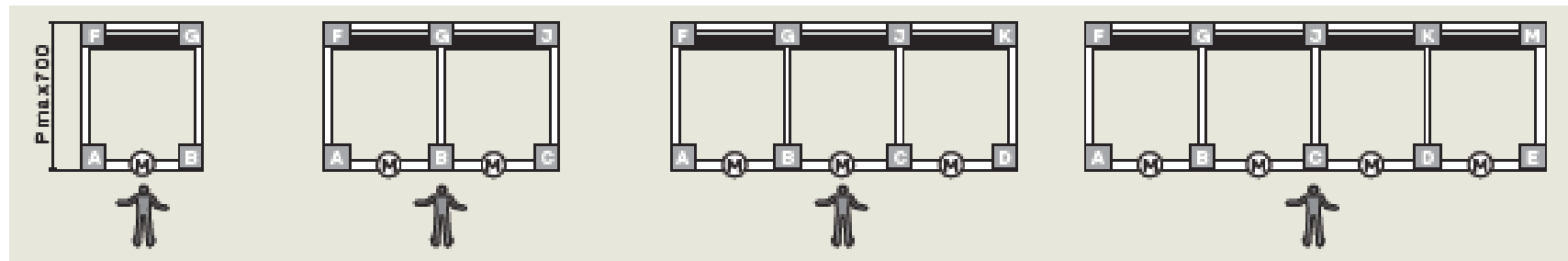

01L : NOMO Free standing con't.

SIDE VIEW

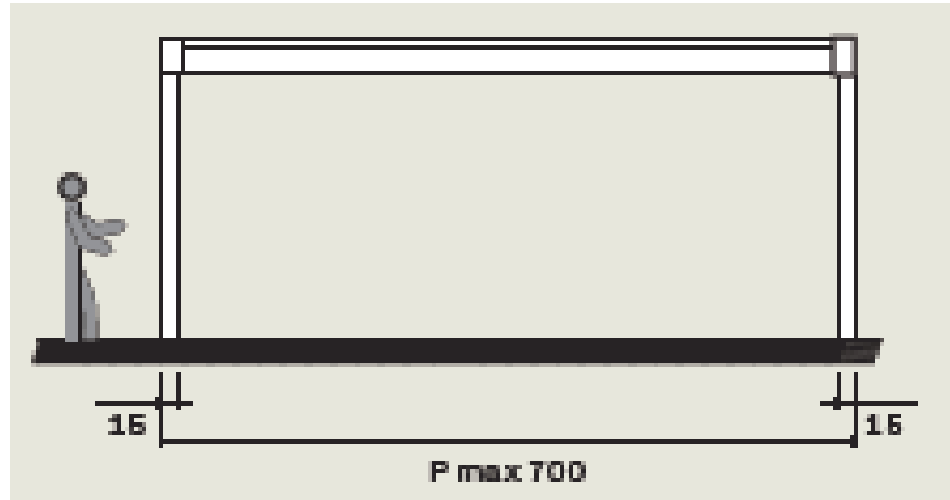

FRONT VIEW

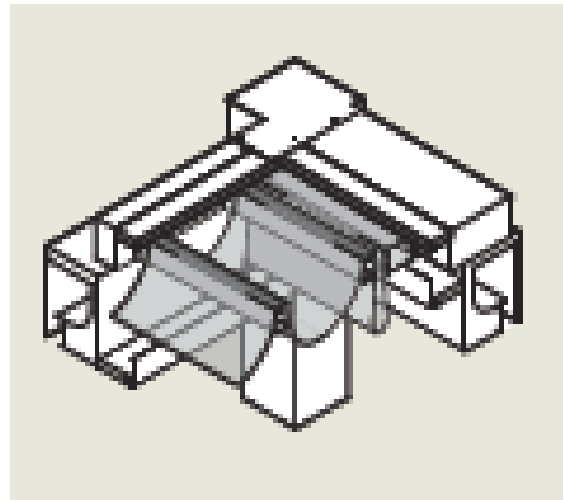
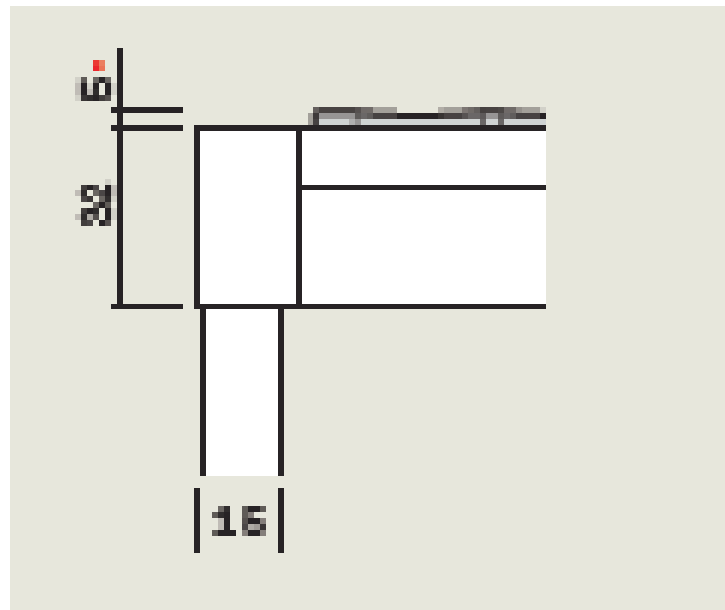
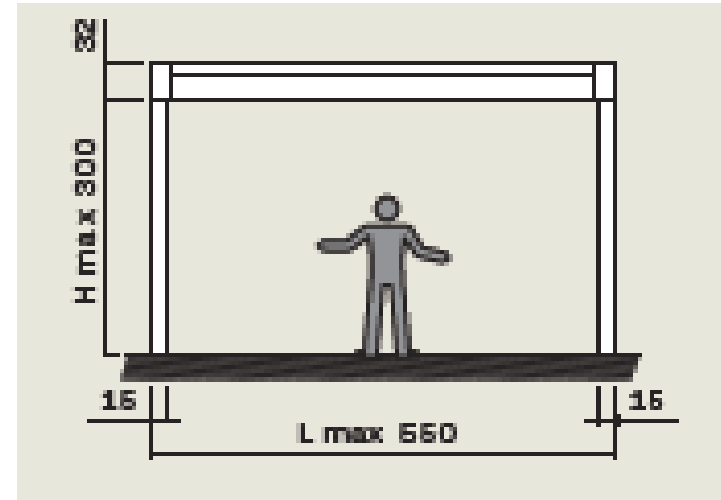

*NOTE: Maximum projection of the cover centered of structure

NOMO 02L : Wall Mounted and if multiple Coupled on projection side.

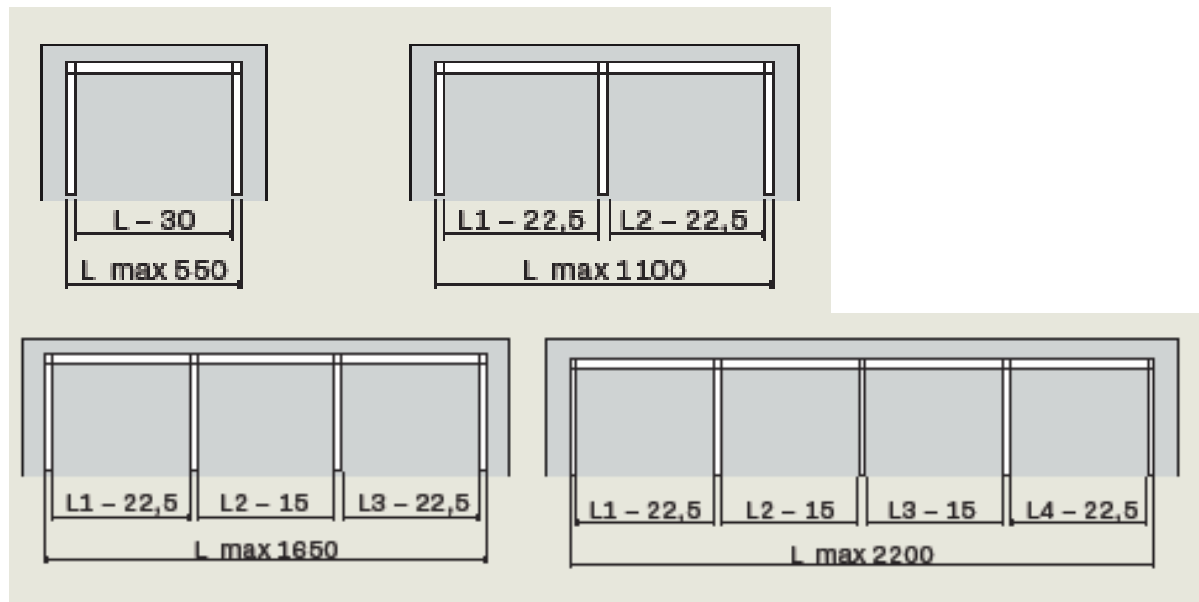
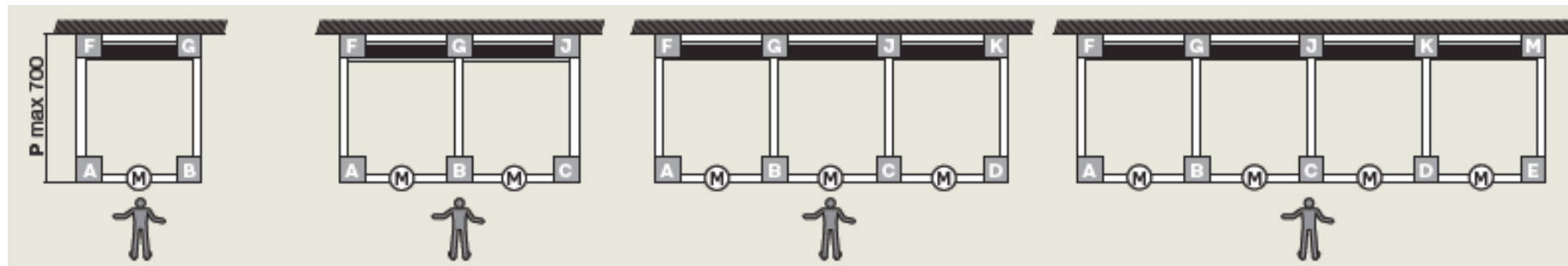

NOMO 02L : Wall Mounted con't.

SIDE VIEW

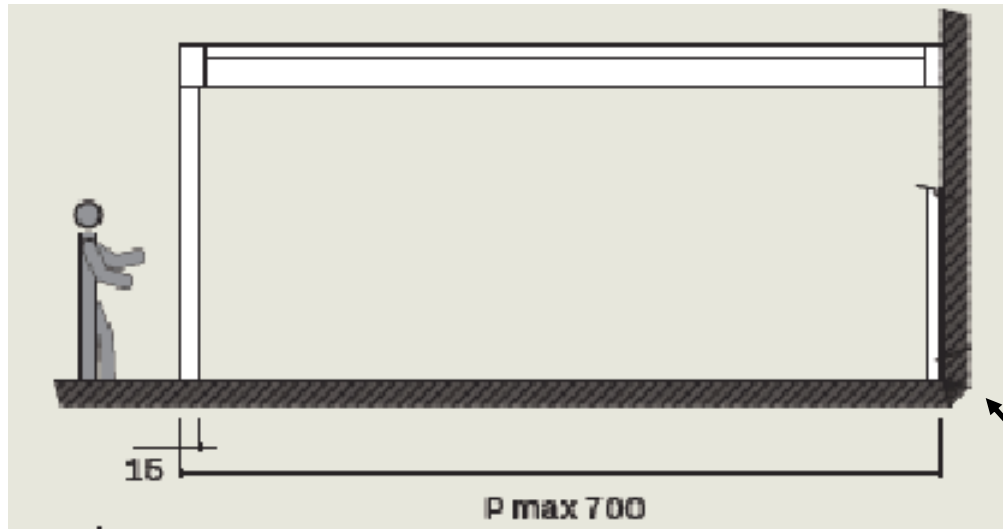

FRONT VIEW

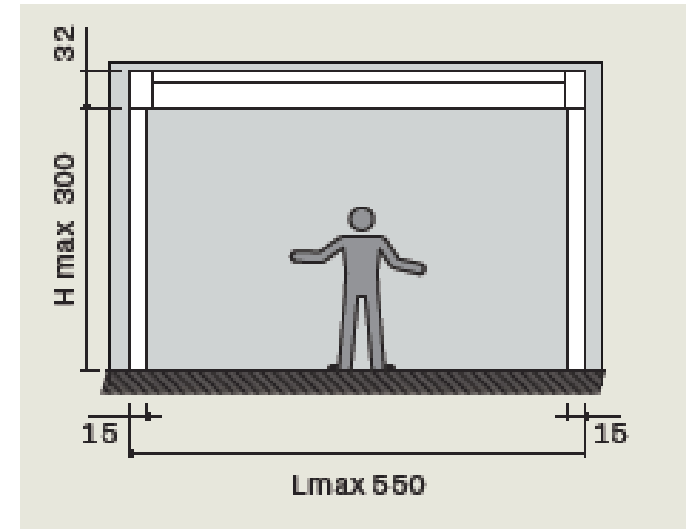

Compensation profile added with RASO screens 10 cm x 15 cm

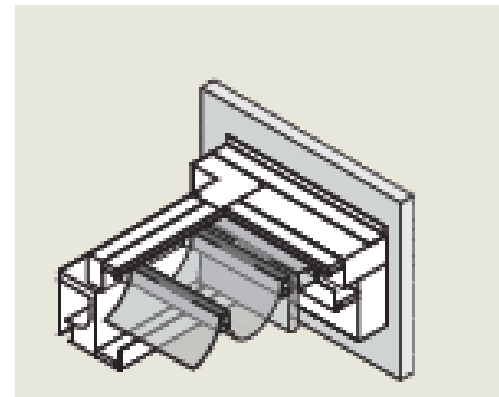
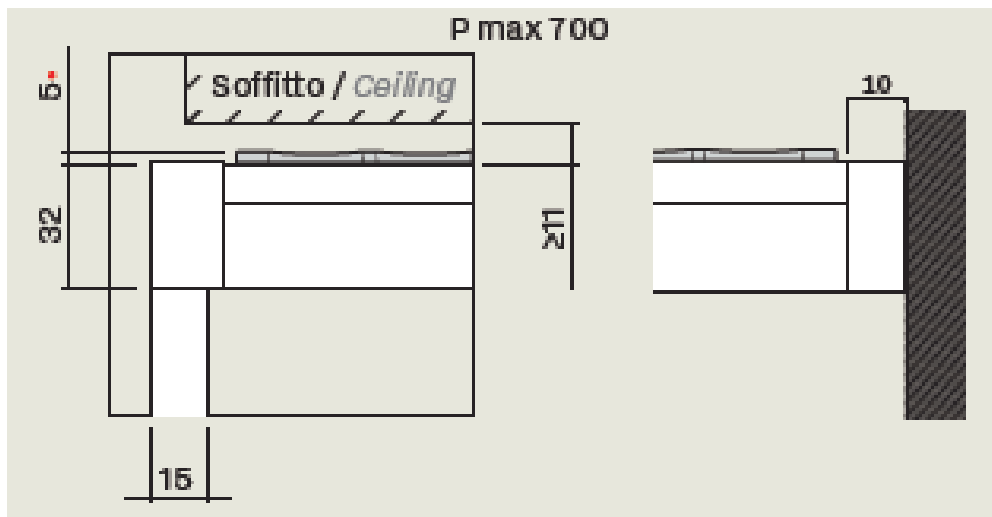

*NOTE: Maximum projection of the cover centered of structure

NOMO 03L : Wall Mounted and if multiple Coupled on width side.

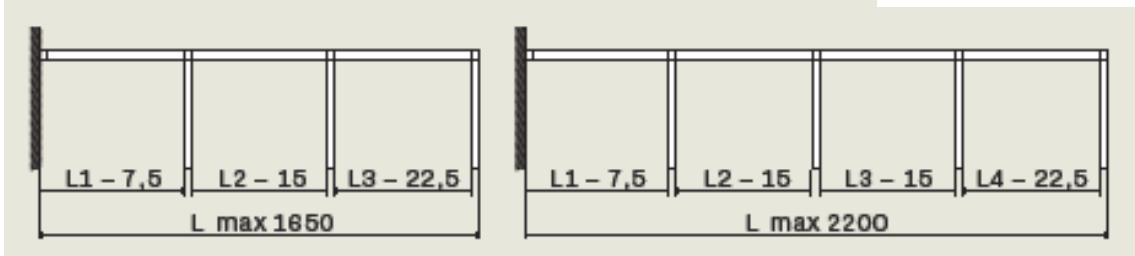
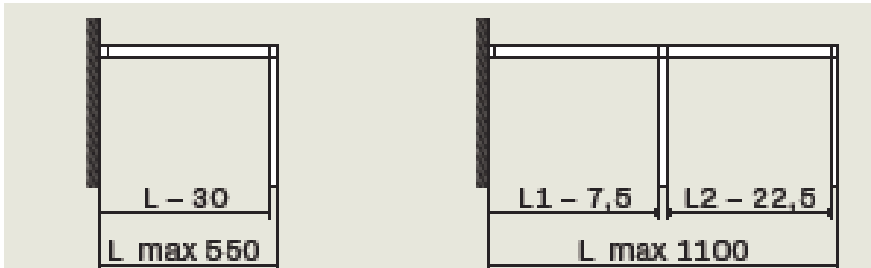
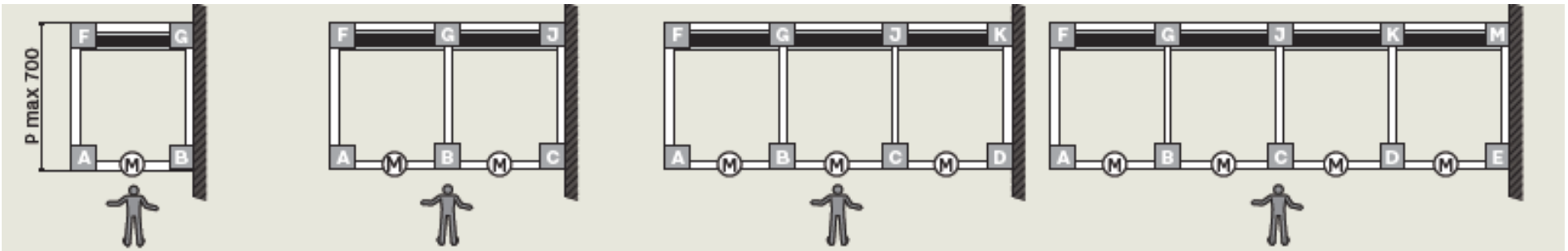
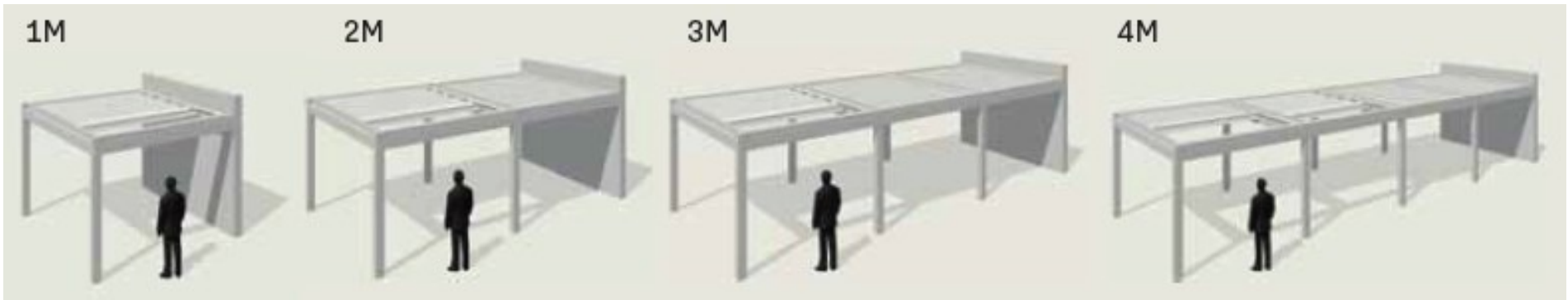

Note:

Drainage capability is reduced on this version due to one side being at the wall.

NOMO 03L : Wall Mounted con't.

SIDE VIEW

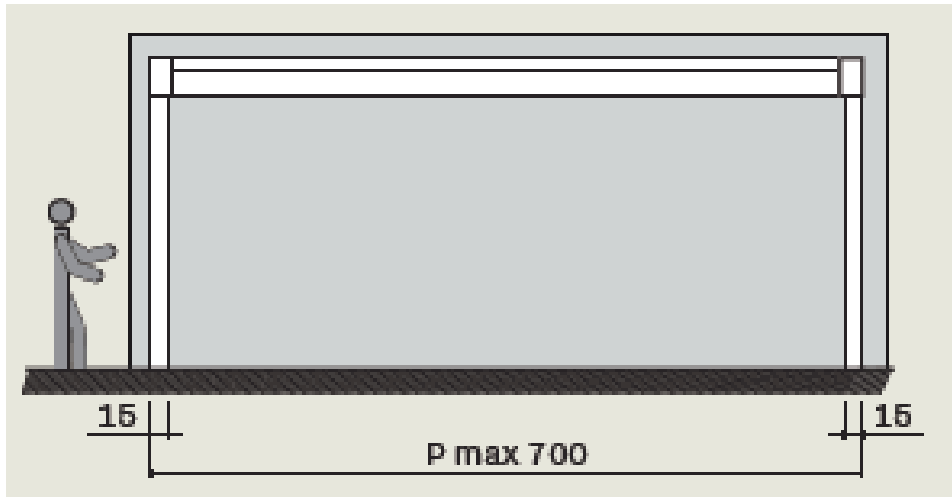

FRONT VIEW

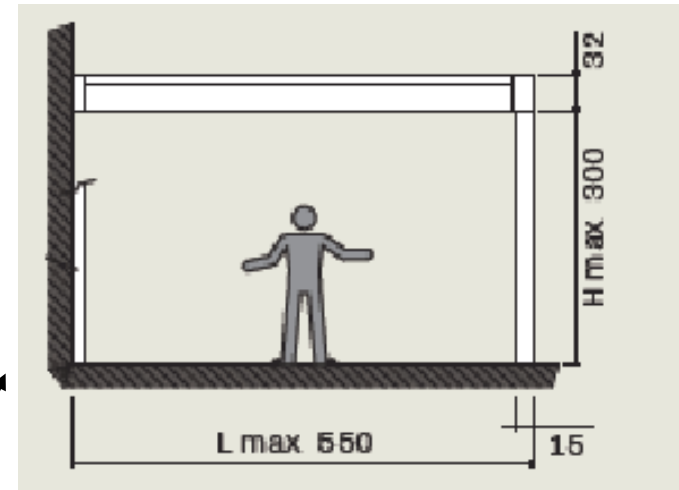

Compensation profile added with RASO screens $10 \text{ cm} \times 15 \text{ cm}$

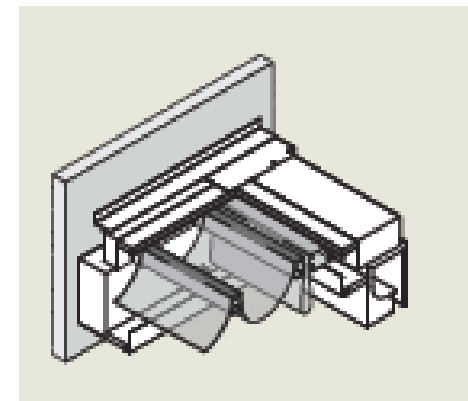
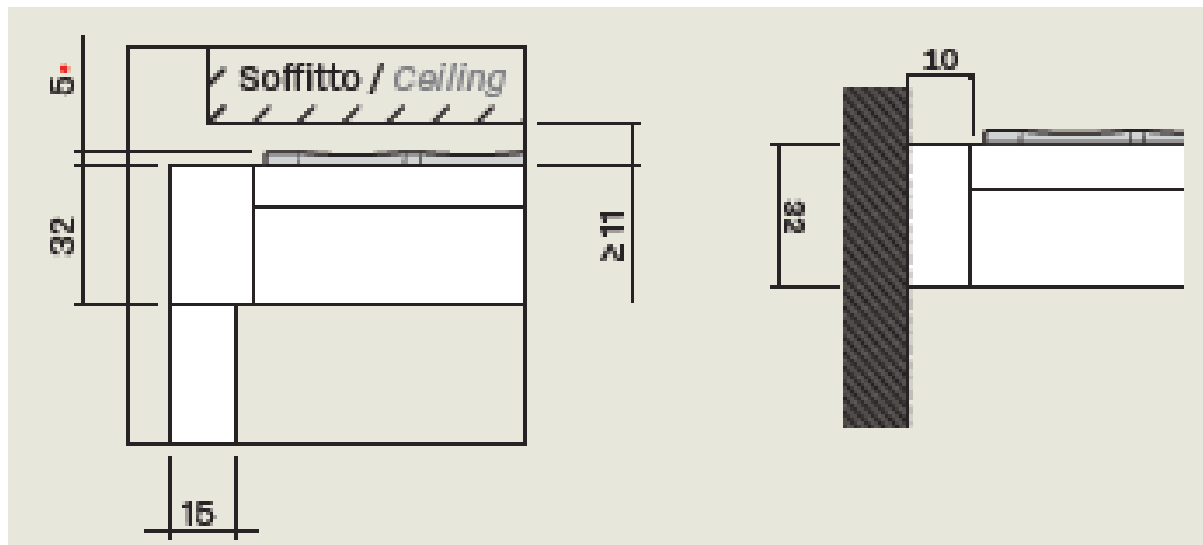

*NOTE: Maximum projection of the cover centered of structure

NOMO 01P : Free Standing and if multiple Coupled on width side.

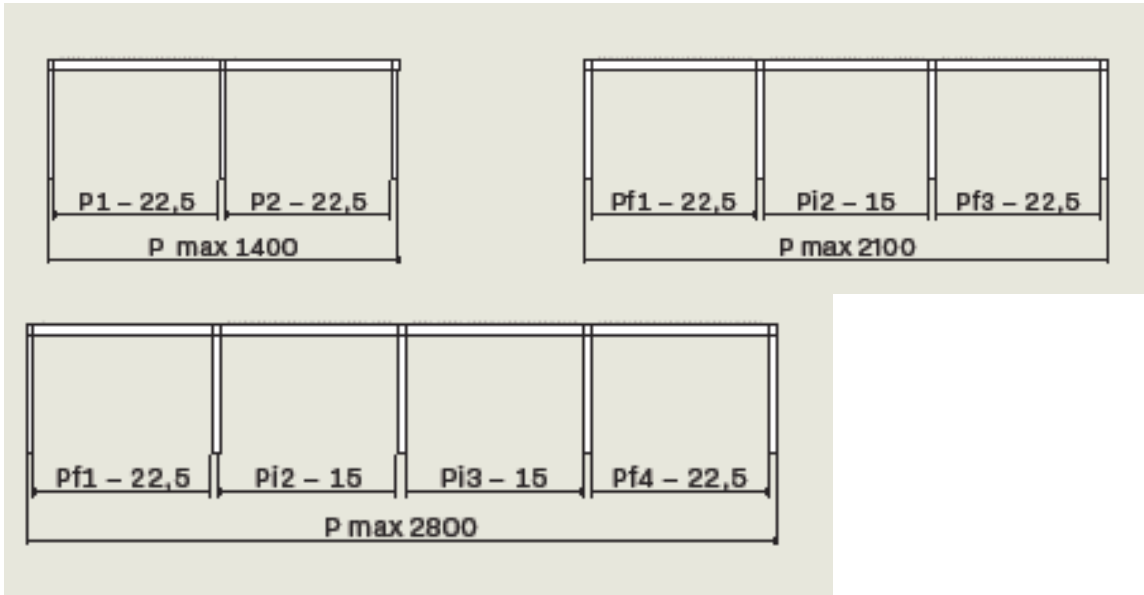
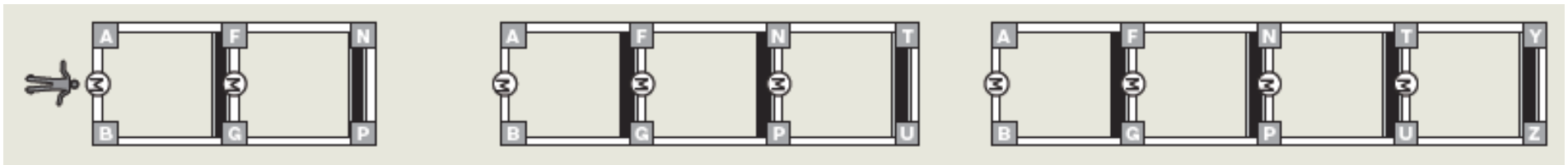

NOMO 01P : Free Standing con't.

SIDE VIEW

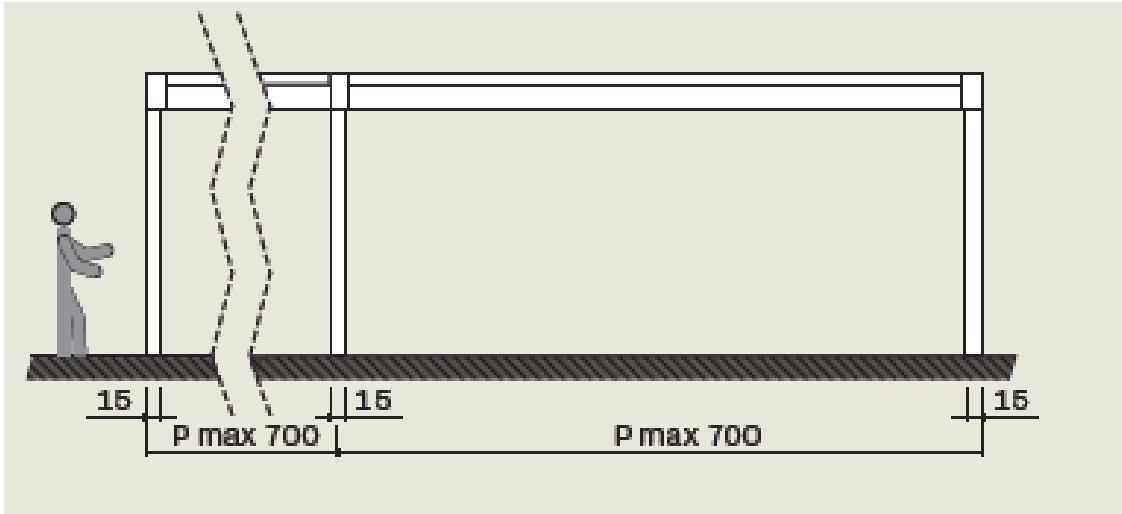

FRONT VIEW

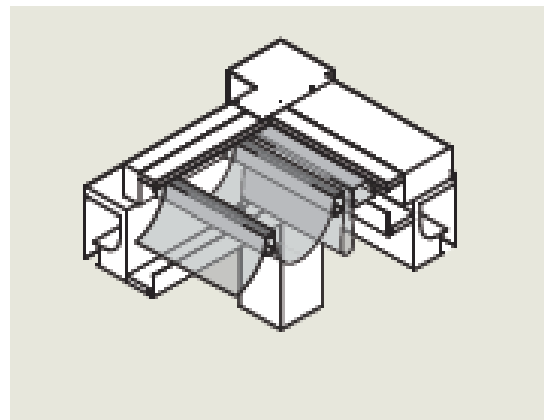
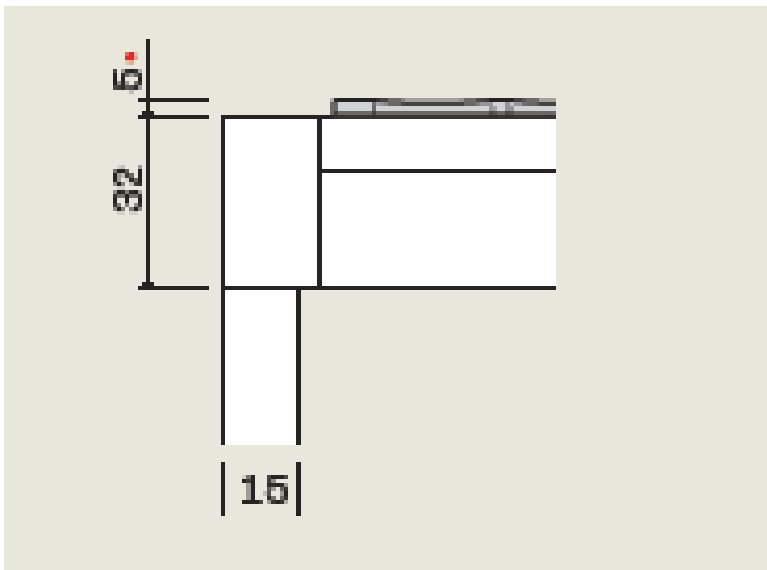
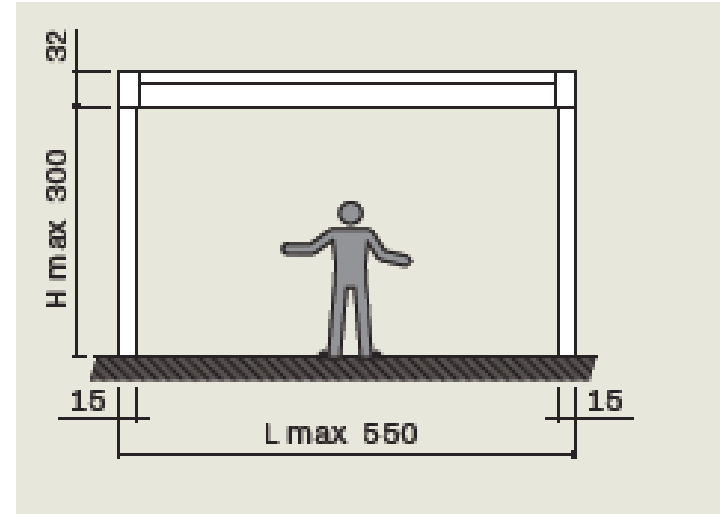

*NOTE: Maximum projection of the cover centered of structure

NOMO 02P : Wall Mounted and if multiple Coupled on width side.

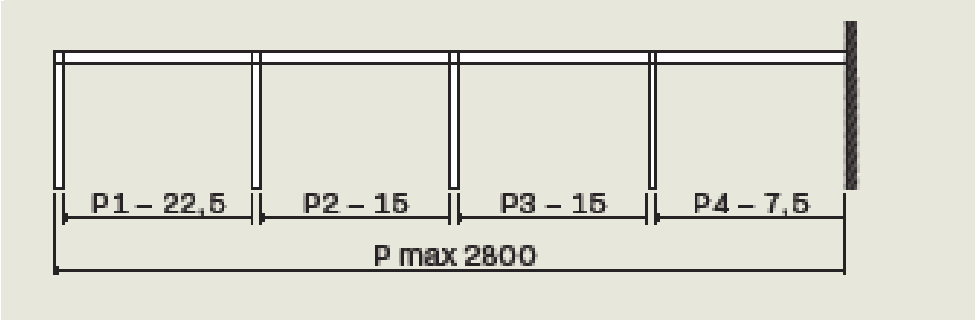
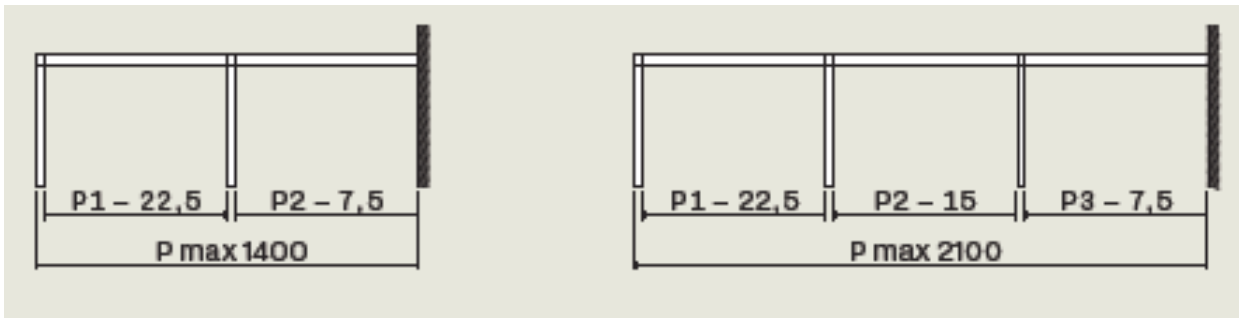
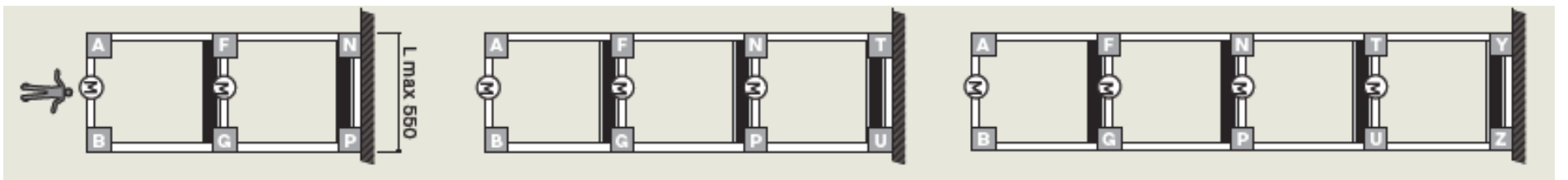

NOMO 02P : Wall Mounted con't.

SIDE VIEW

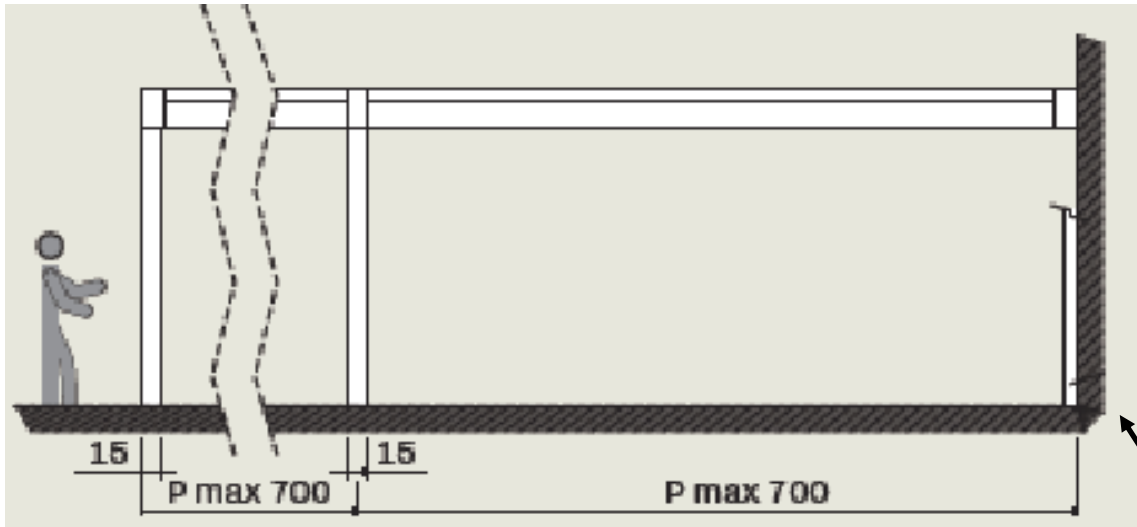

FRONT VIEW

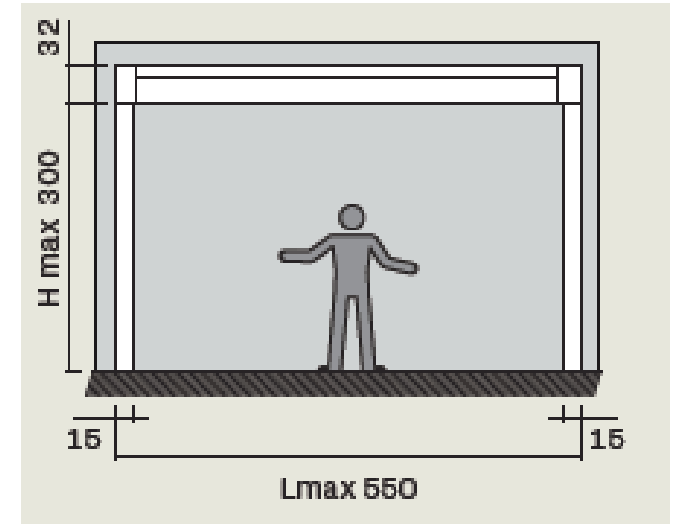

Compensation profile added with RASO screens 10 cm x 15 cm

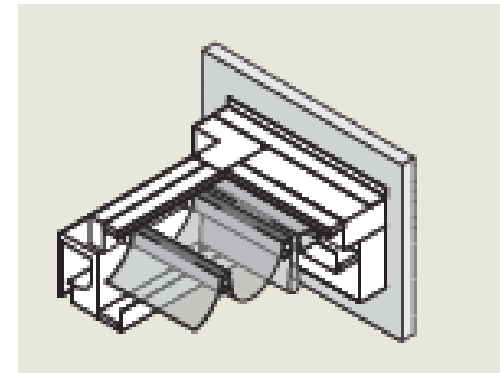
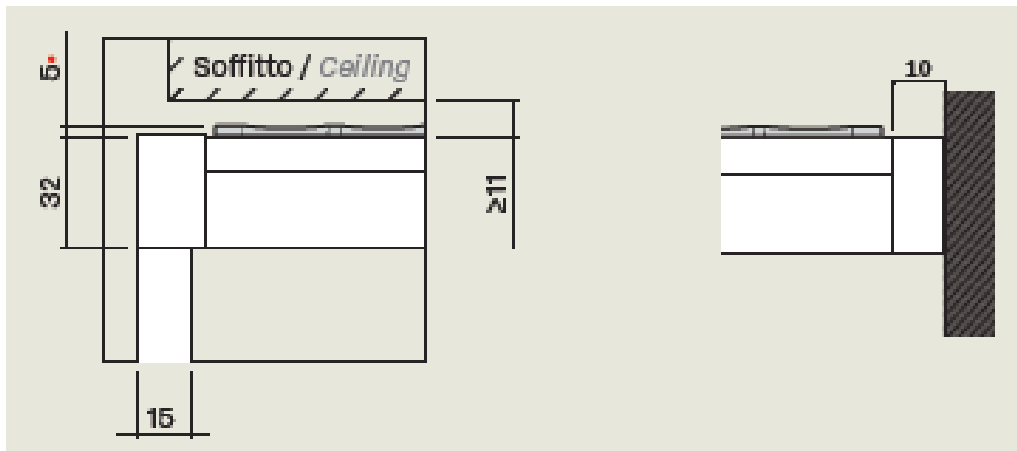

*NOTE: Maximum projection of the cover centered of structure

NOMO 03P : Wall Mounted and if multiple Coupled on Projection side.

2M



3M



4M

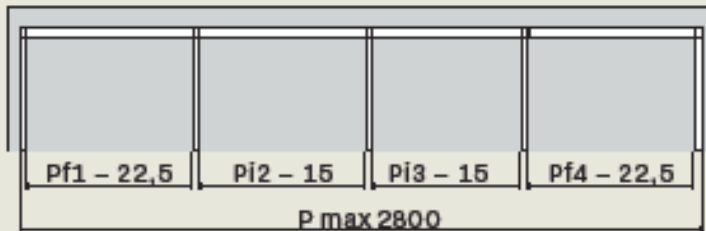
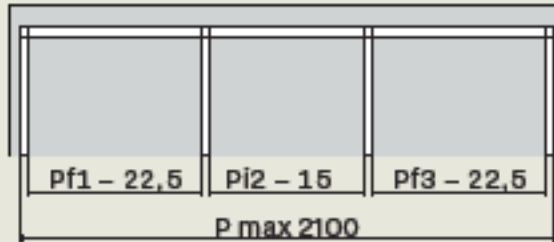
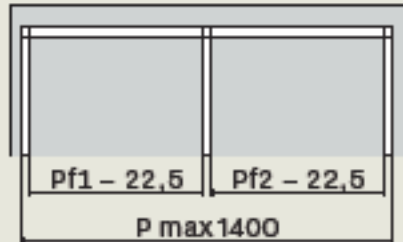
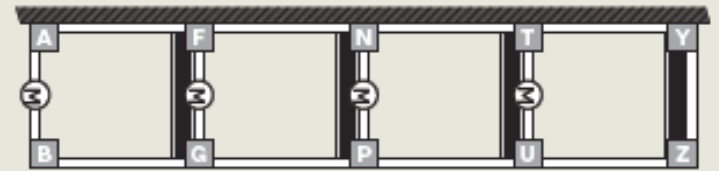
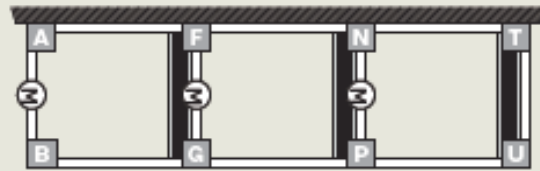
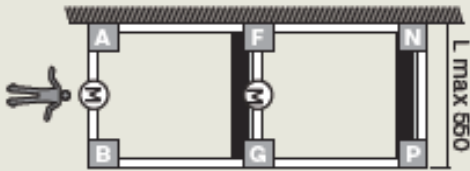

Note:

Drainage capability is reduced on this version due to one side being at the wall.

NOMO 03P : Wall Mounted con't.

SIDE VIEW

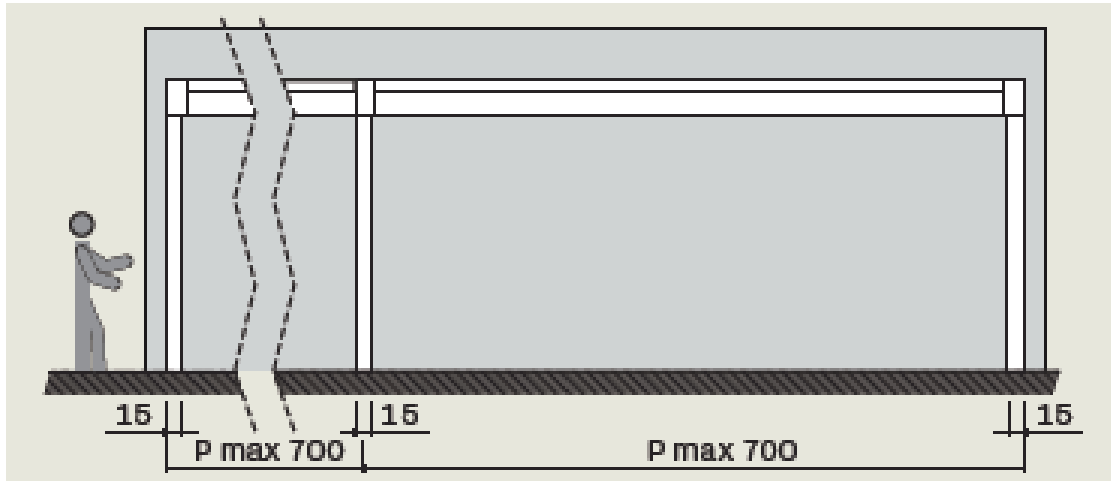

FRONT VIEW

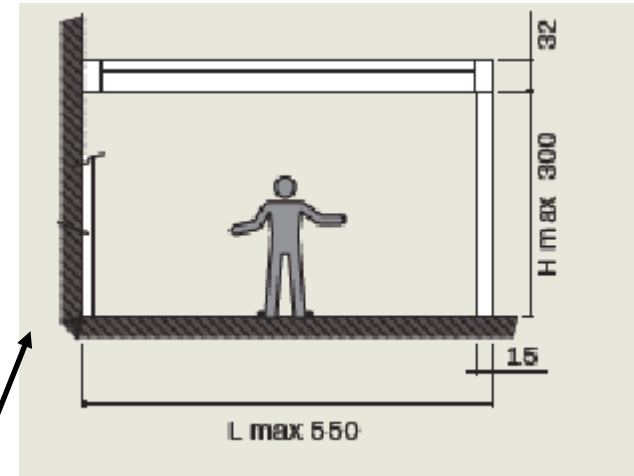

Compensation profile added with RASO screens 10 cm x 15 cm

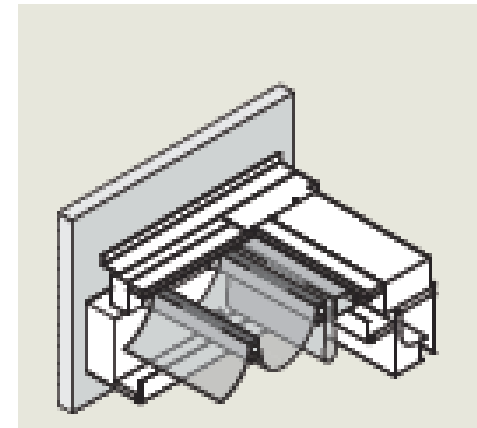
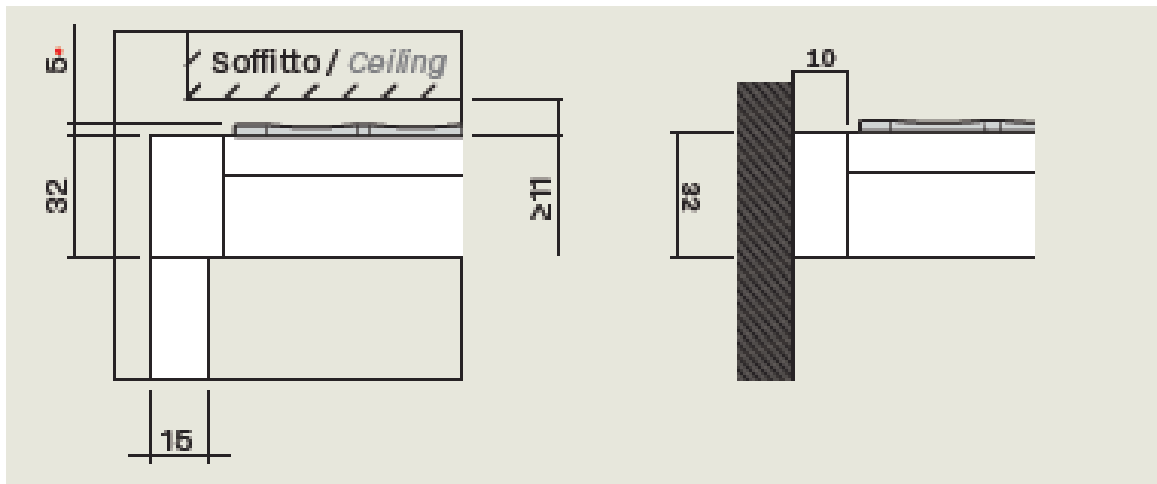

*NOTE: Maximum projection of the cover centered of structure

Multiple NOMO structures can be combined to cover larger spaces both in width and projection. To couple units together middle beams and posts are deducted from the configuration.

Max size one unit with 4 posts / 1 span fabric

L = width = from 6' 6" to 18' wide (550 cm)

P = projection = from 6' 6" to 22' 11" projection (700 cm)

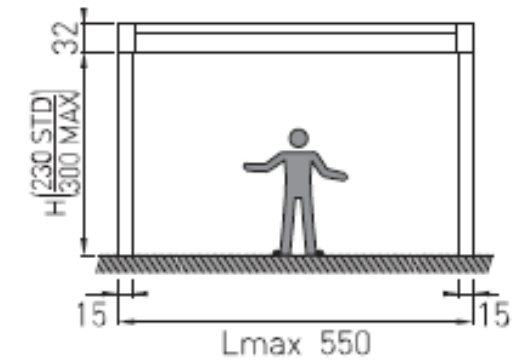
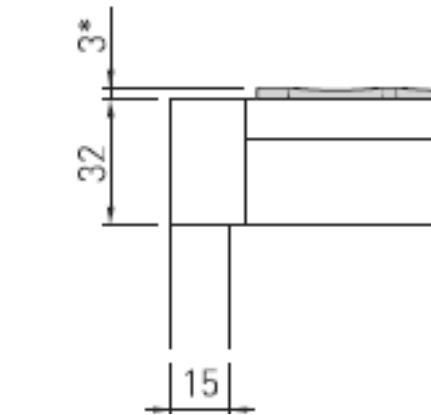
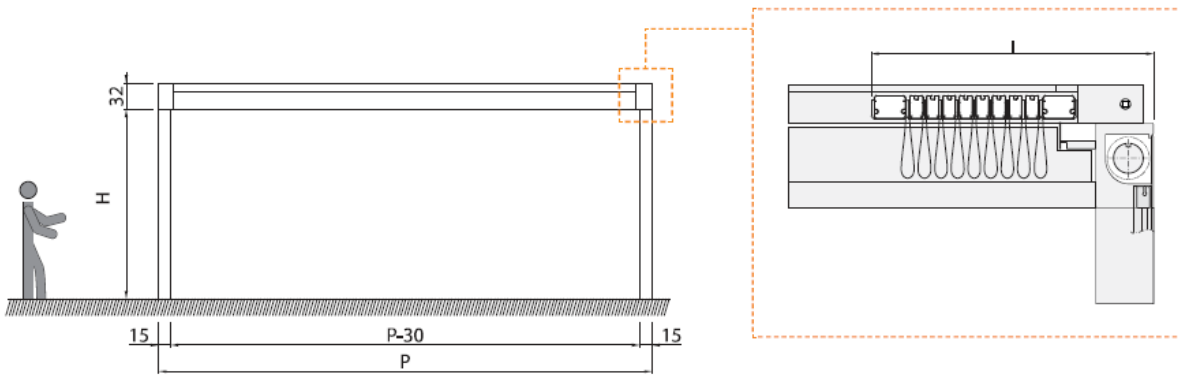

Front view

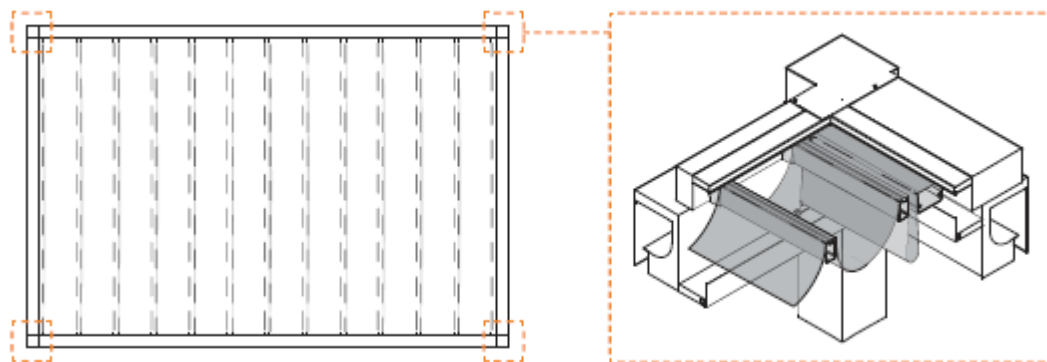

Top view

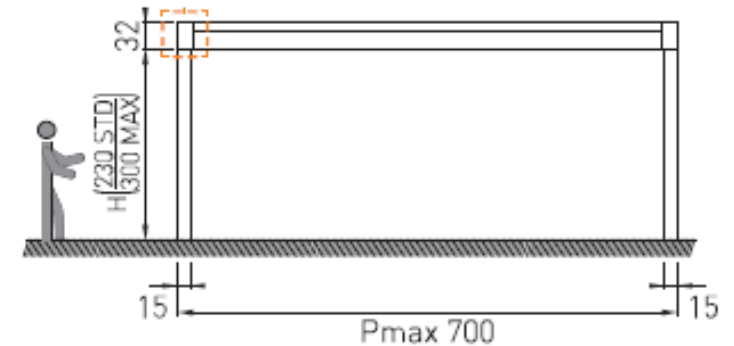

Side view

NOMO Technical Details.

Supporting Box Profile with Raso shown

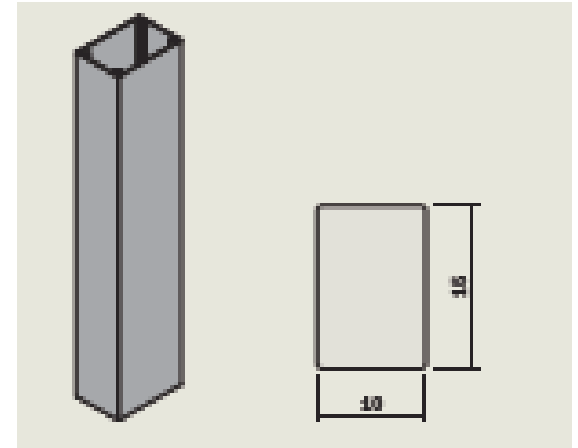
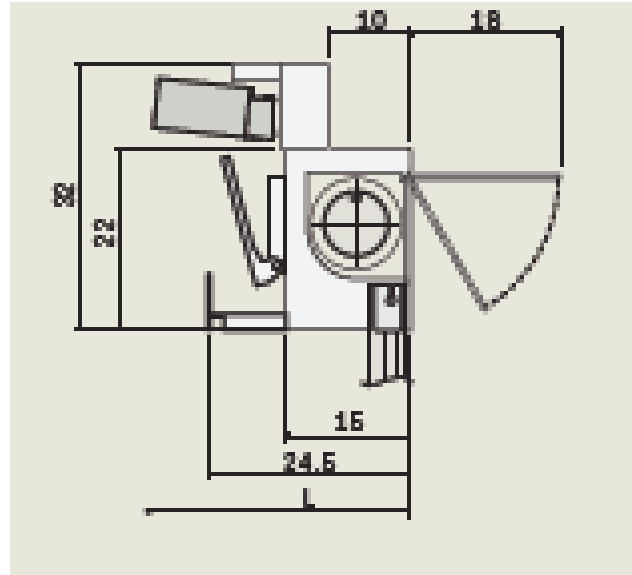
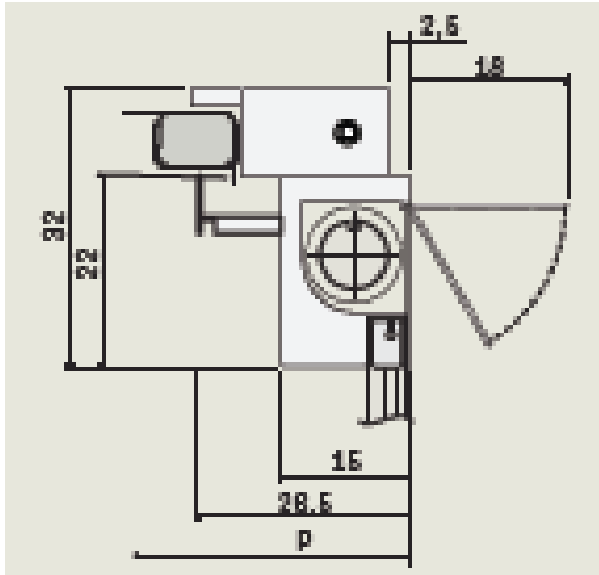

Compensation Profile 10 x 15 cm

Intermediate Supporting Profile

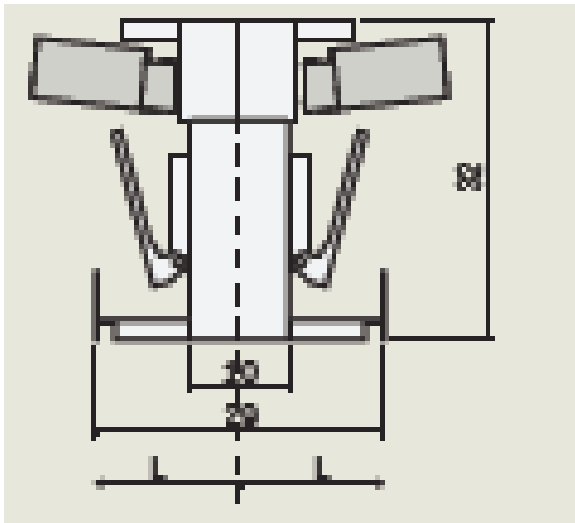

Post Profile

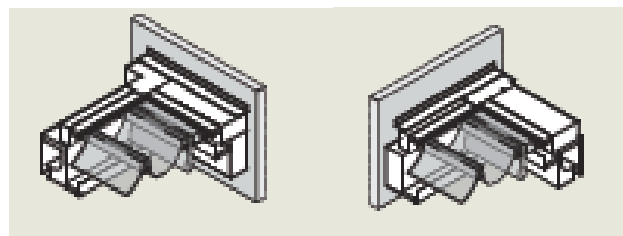
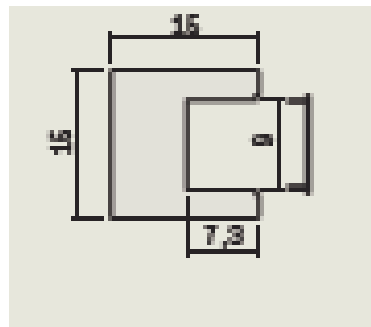

Wall Mounting With Profile

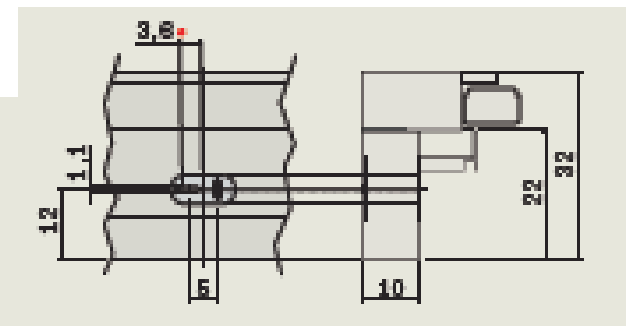

NOMO More Technical Details.

Tilting Gutter

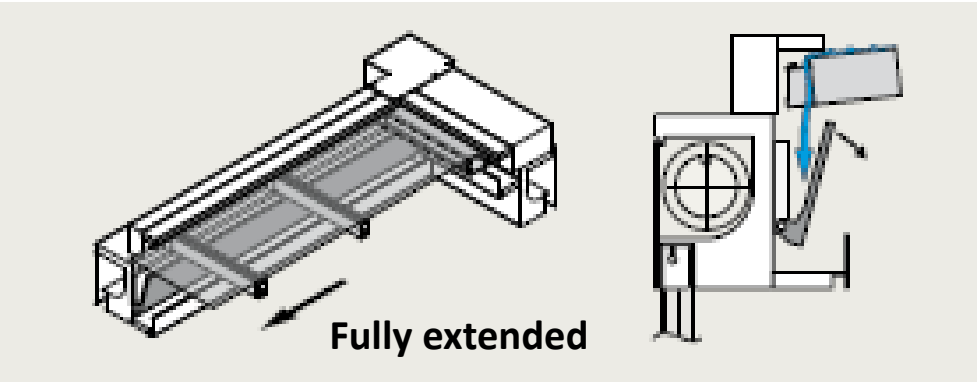
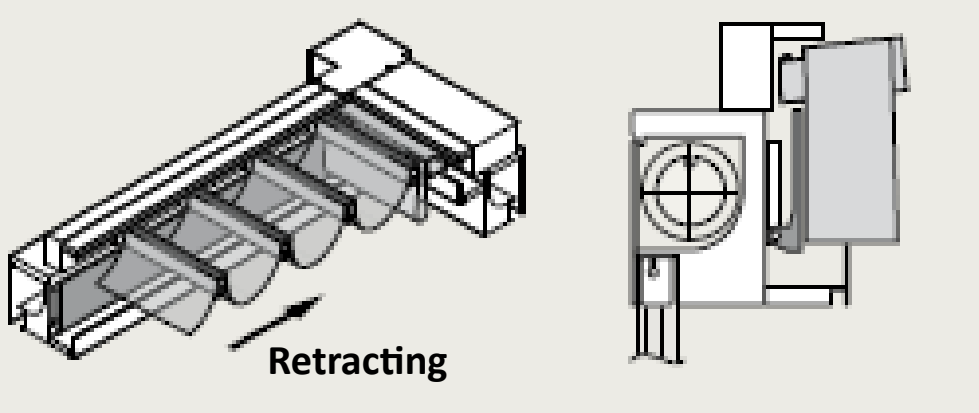

NOMO Post options.

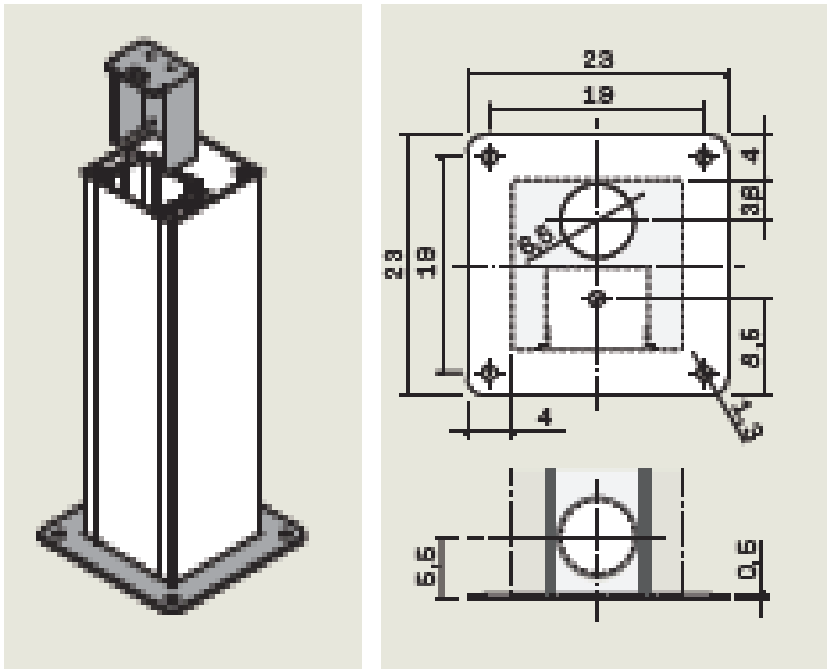

STANDARD POST & FOOT PLATE

POST HEIGHTS:

Standard under gutter 90" (230 cm)

Up to 98" no additional cost. (250 cm)

Above 98" extra cost per post.

NOMO: Max height posts 118" (300 cm)

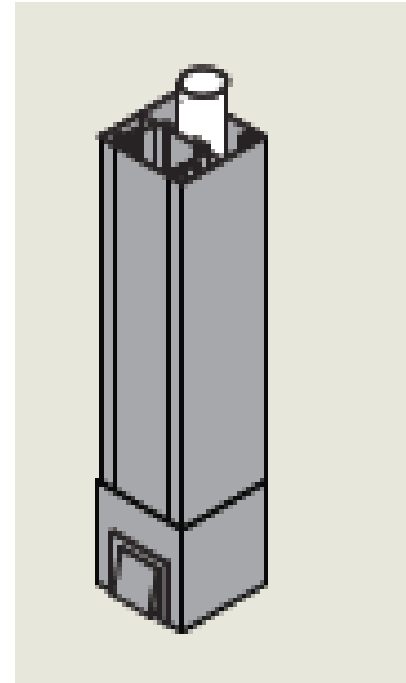

TELESCOPING FEET

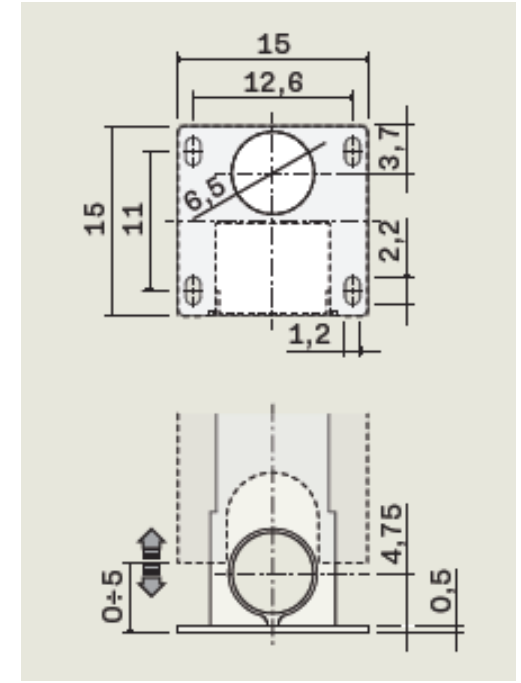

Post profile For compensation to the wall of RASO awning fixing (only for versions 02L or 02P), it is supplied as standard if the Raso awning is ordered together with the structure. The fixing method of the post profile is at the discretion of the installer.

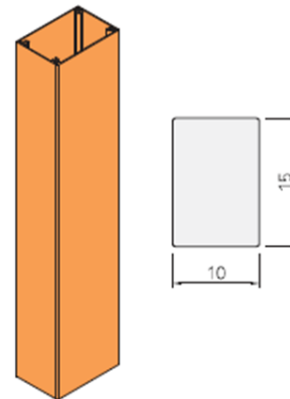

The "post" plate is as follows:

stainless steel 0.5 cm thick =
3/16" thick

Holes on center side to side along
front 11 cm = 4.33 inches

Holes on center front to
back apart 2.6 cm = 4.96 inches

NOMO Post drainage options.

Front drainage option

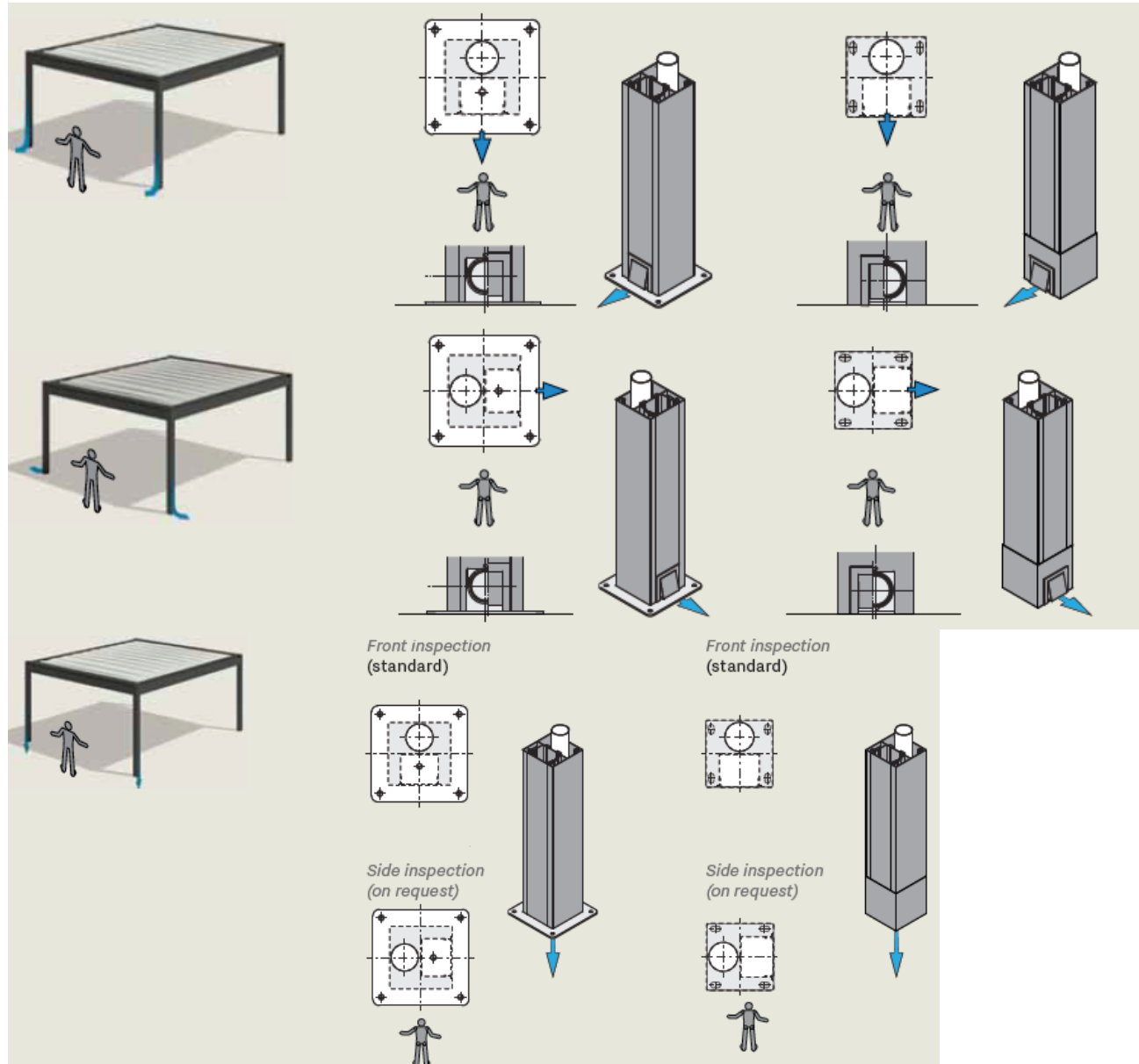

NOTE: The NOMO fabric is arched on the top so a drainage points are needed on each side of each module. Two drainage points per module is minimum (More is better).

RIALTO

01L : Free standing and if multiple Coupled on projection side.

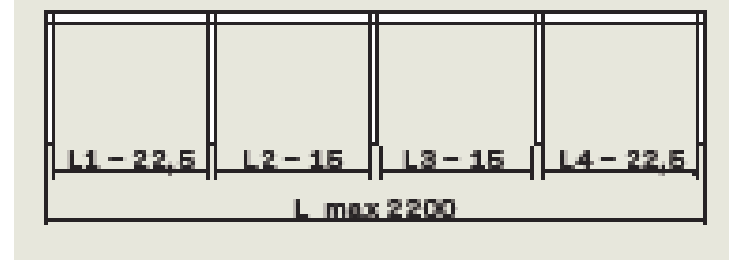
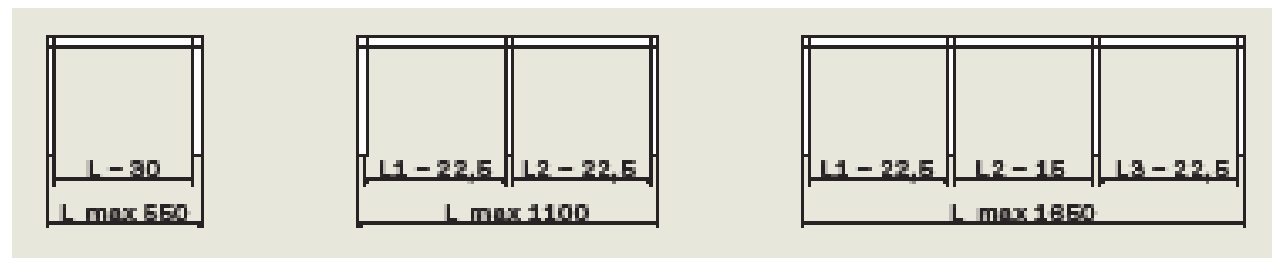
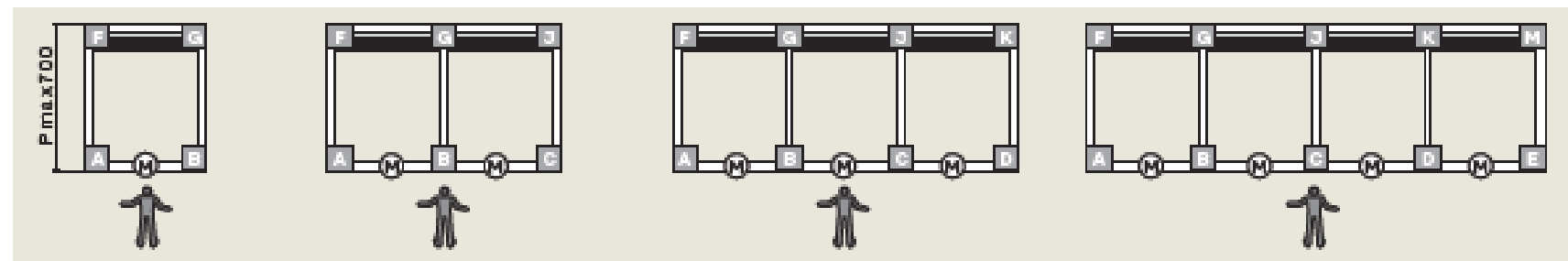

Note: Raso screens not available with RIALTO model.

01L : RIALTO Free standing con't.

SIDE VIEW

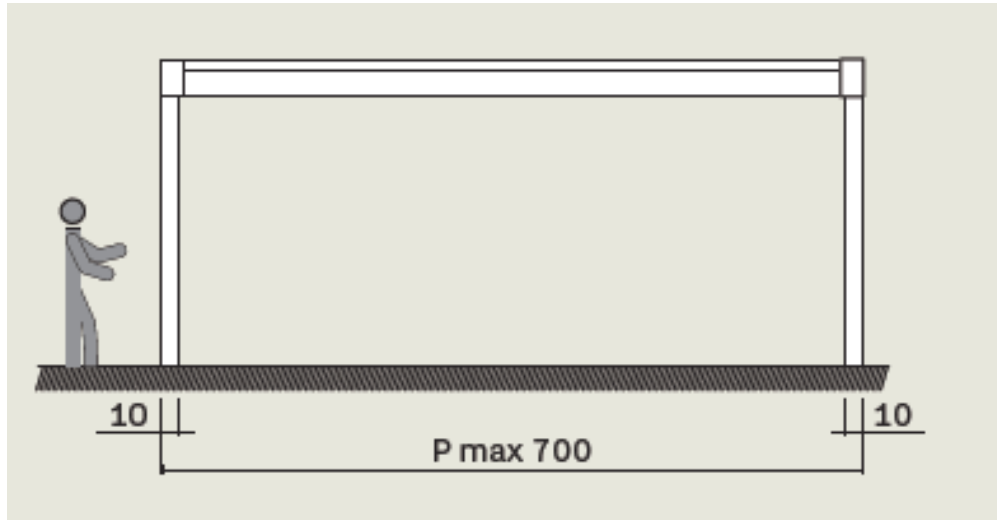

FRONT VIEW

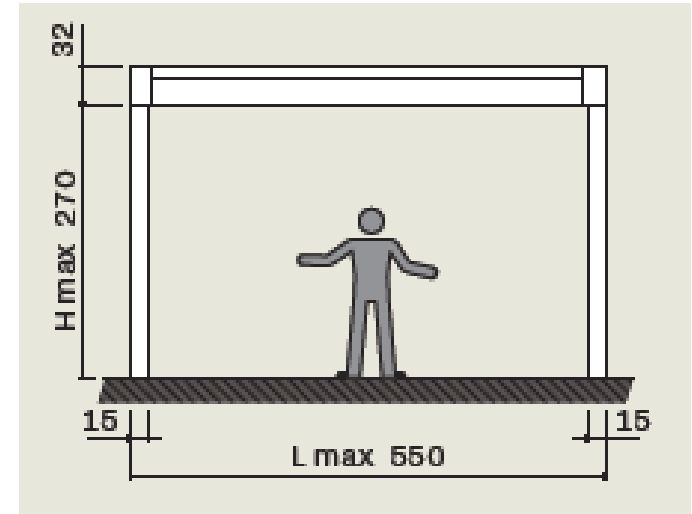

*NOTE: Maximum projection of the cover centered on post at front

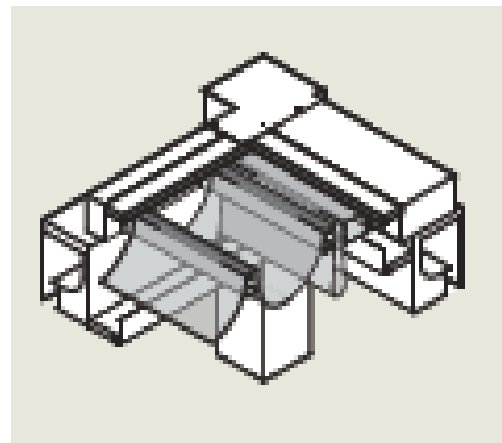
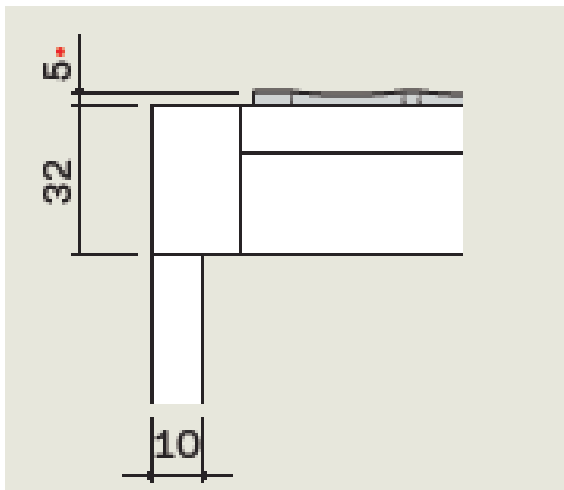

*NOTE: Maximum projection of the cover centered of structure

RIALTO 02L : Wall Mounted and if multiple Coupled on projection side.

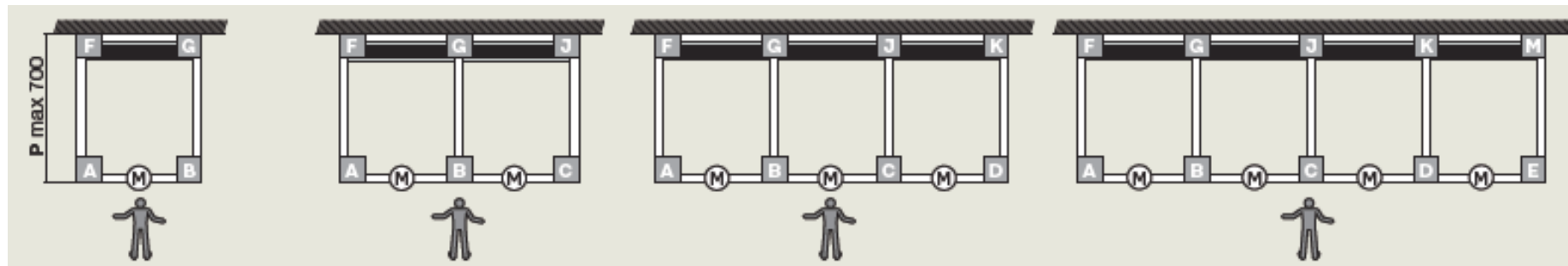

Note: Raso screens not available with RIALTO model.

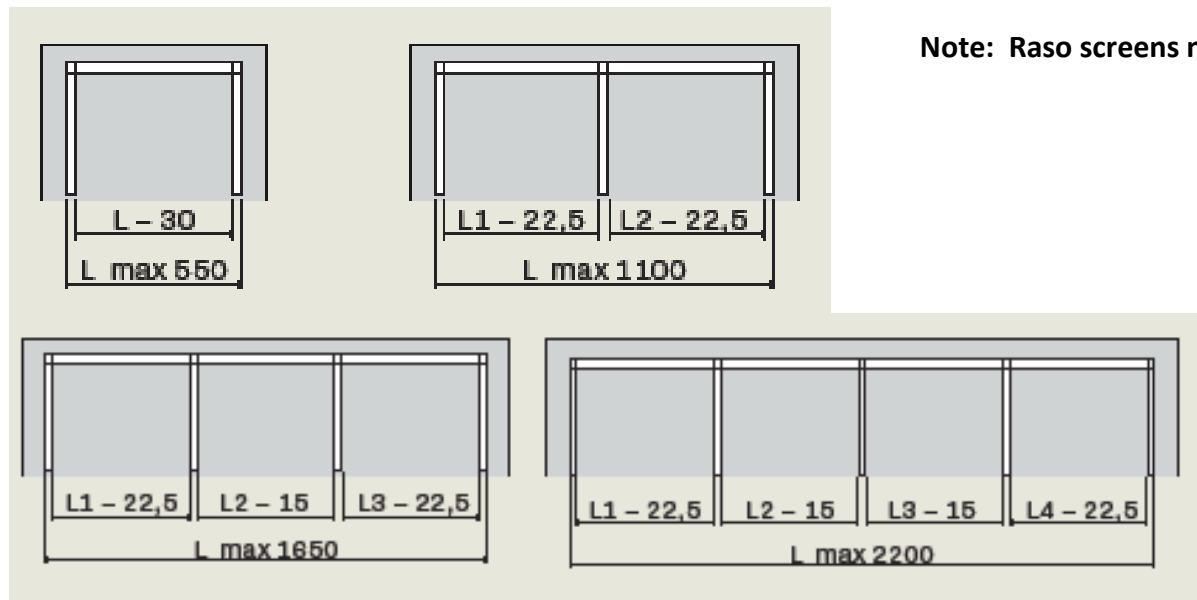

RIALTO 02L : Wall Mounted con't.

SIDE VIEW

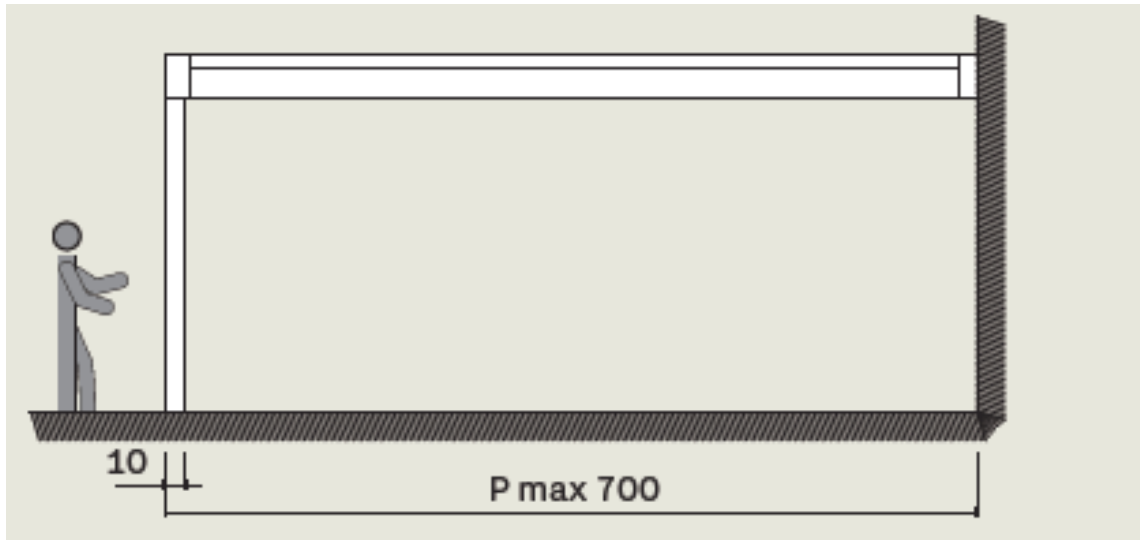

FRONT VIEW

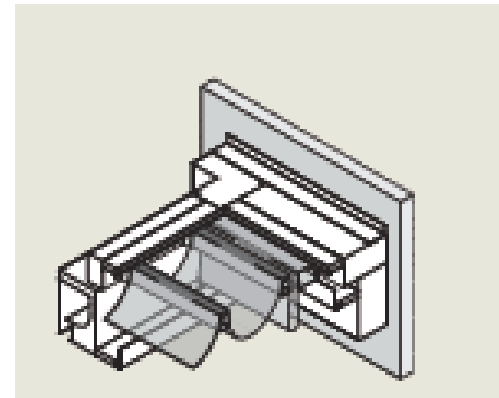
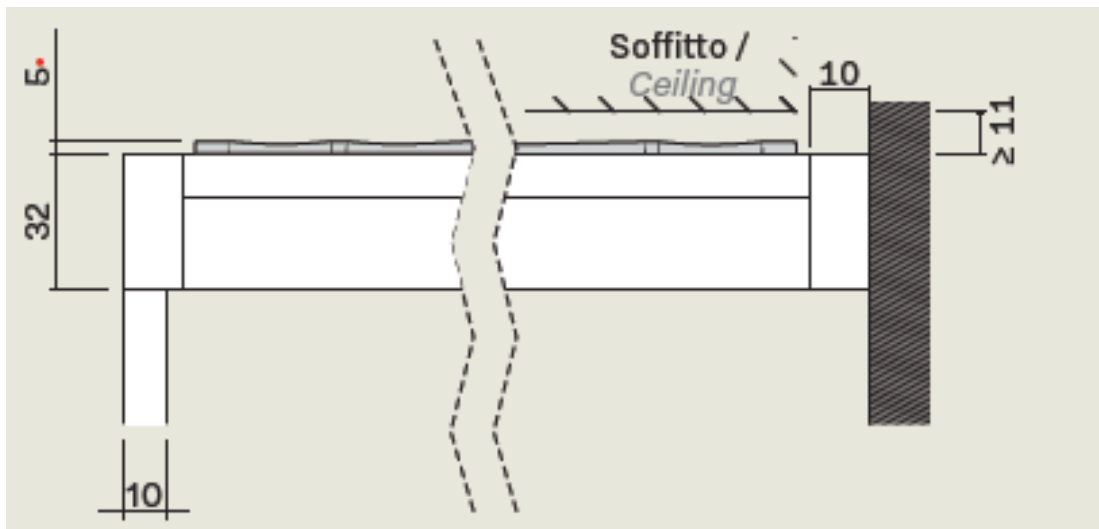
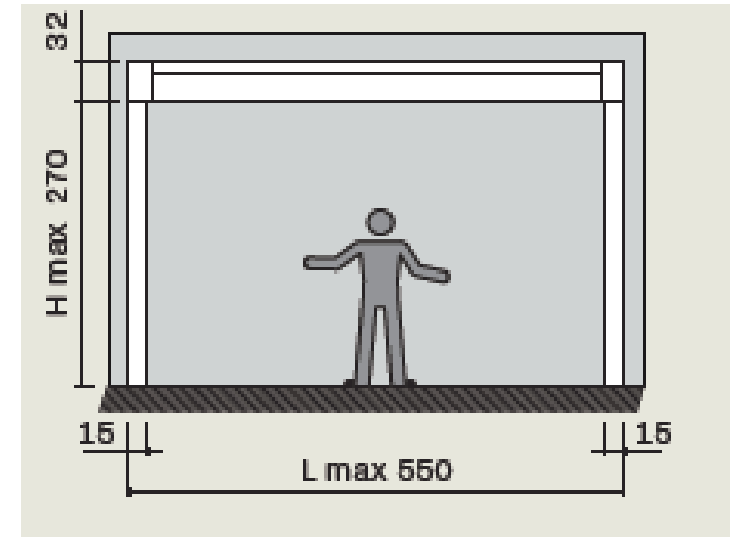

*NOTE: Maximum projection of the cover centered on post at front

RIALTO 03L : Wall Mounted and if multiple Coupled on width side.

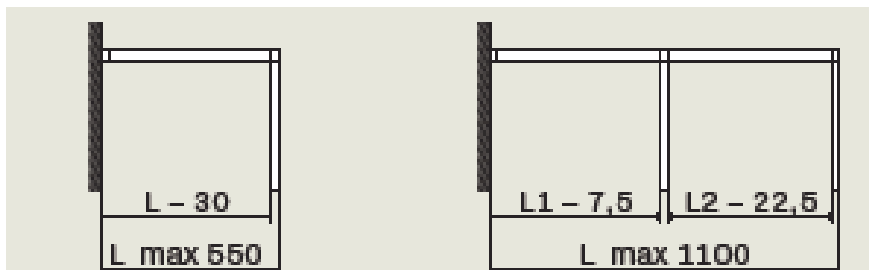
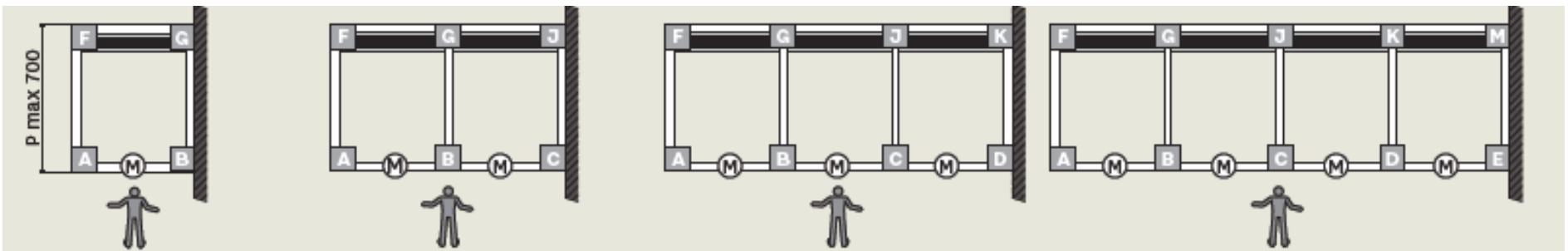
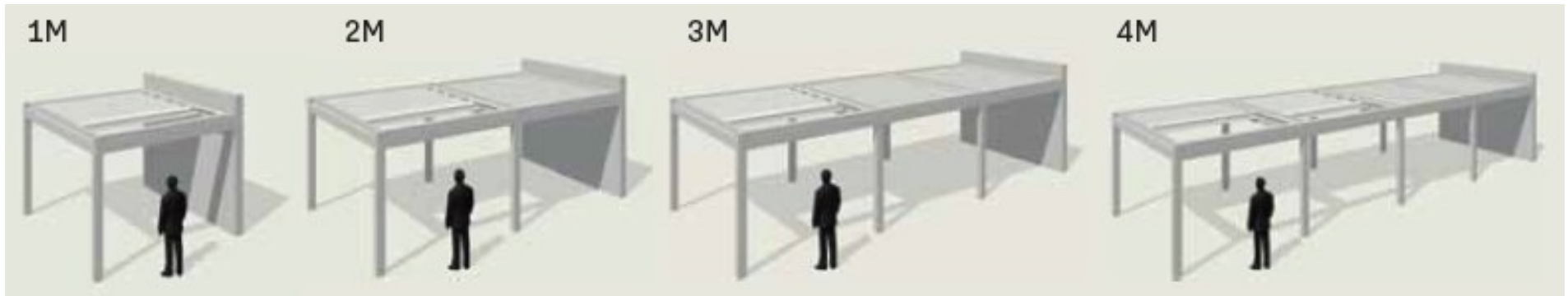

Note:

Drainage capability is reduced on this version due to one side being at the wall.

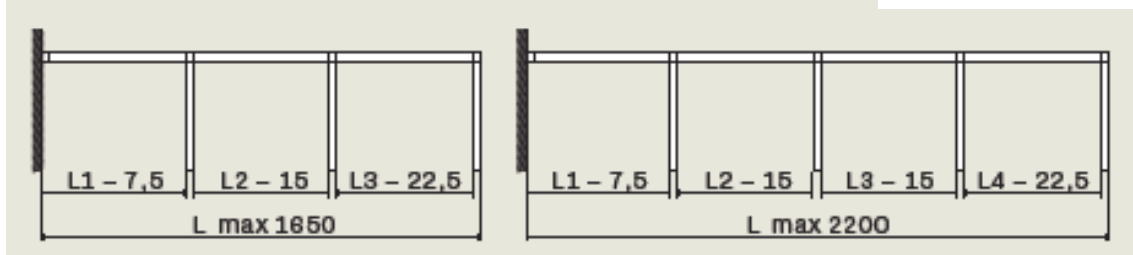

Note:

Raso screens not available with RIALTO model.

RIALTO 03L : Wall Mounted con't.

SIDE VIEW

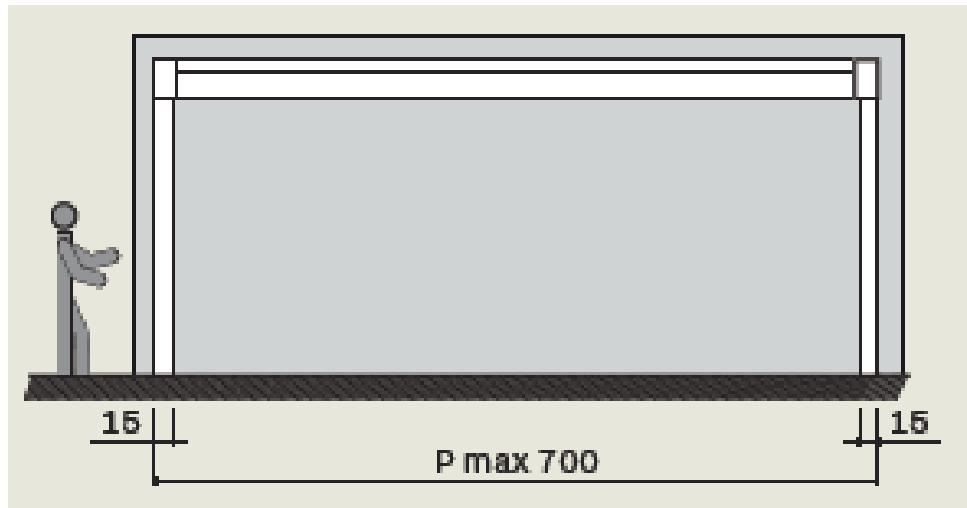

FRONT VIEW

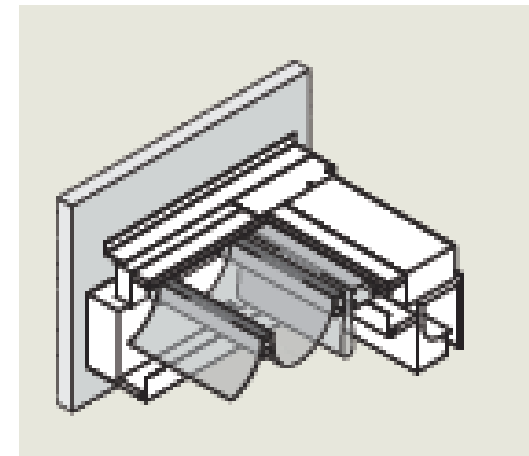
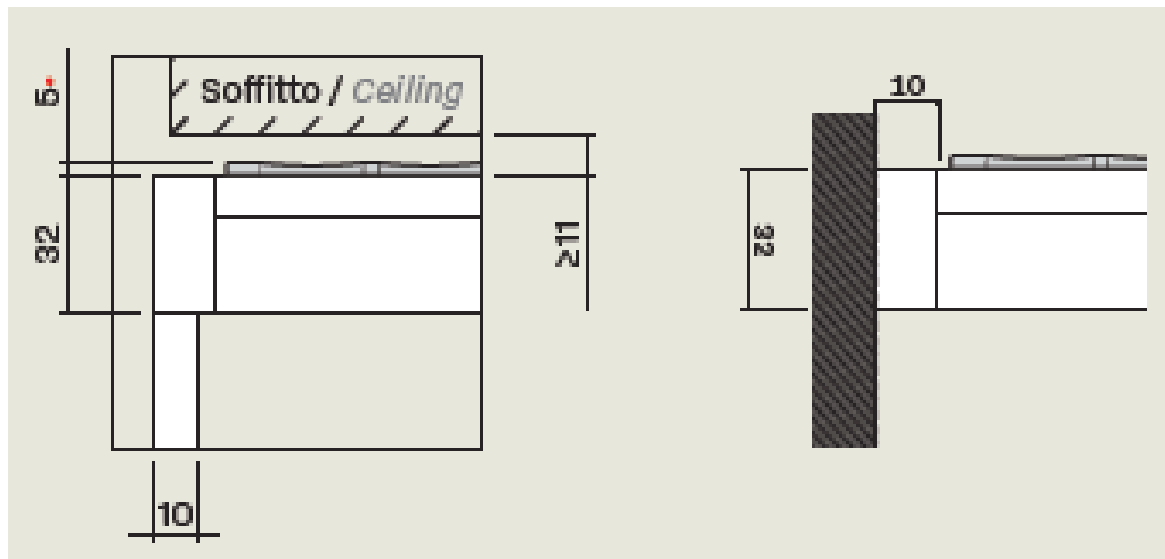
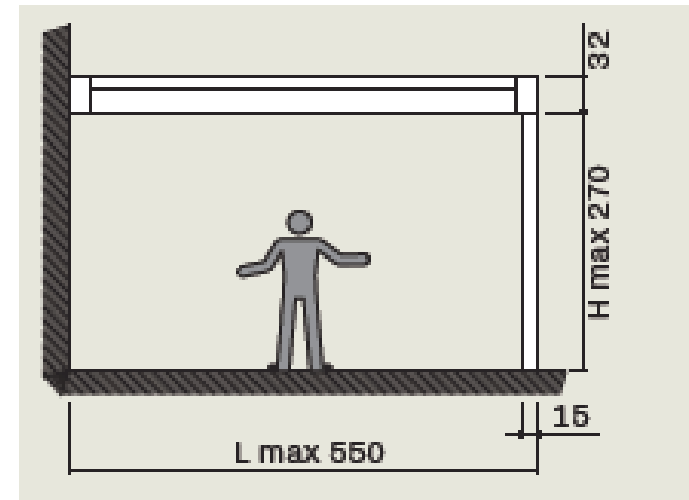

*NOTE: Maximum projection of the cover centered on post at front

RIALTO 01P : Free Standing and if multiple Coupled on width side.

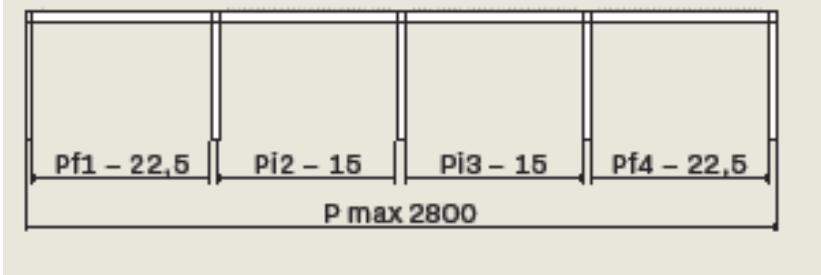
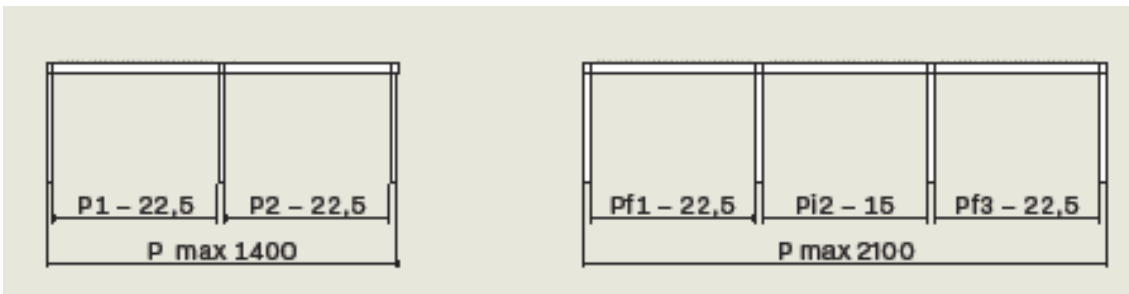
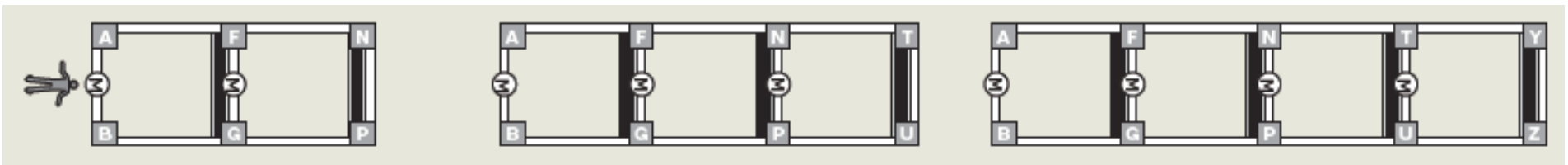

Note: Raso screens not available with RIALTO model.

RIALTO 01P : Free Standing con't.

SIDE VIEW

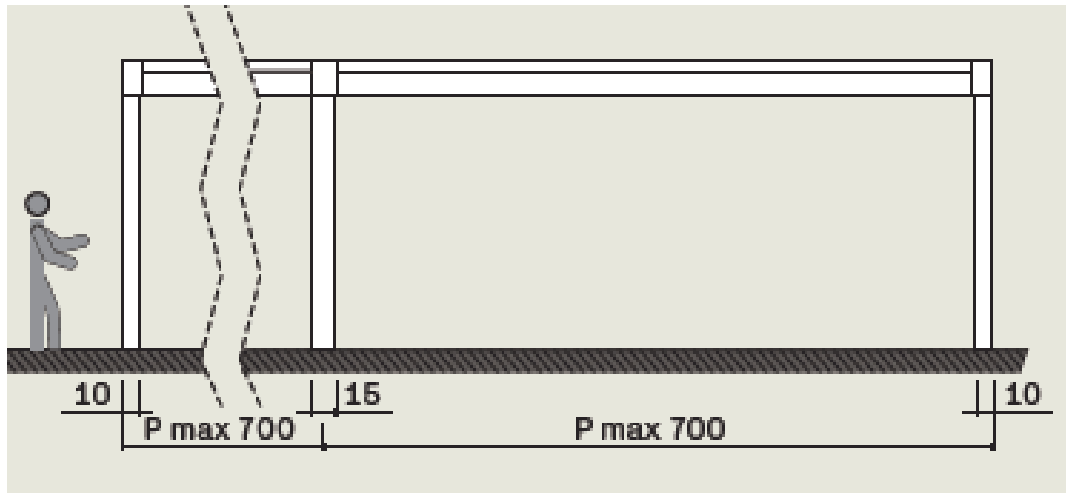

FRONT VIEW

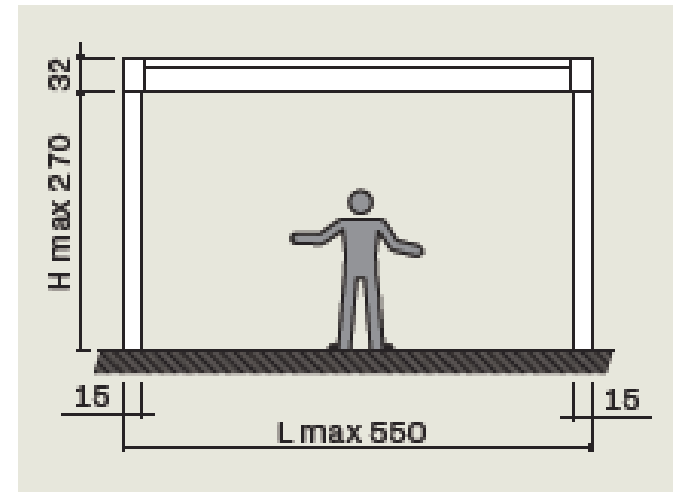

*NOTE: Maximum projection of the cover centered on post at

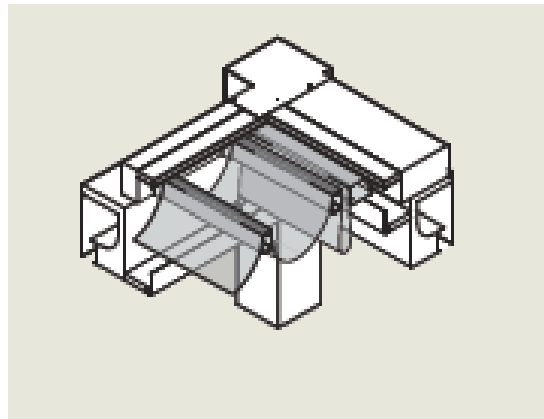
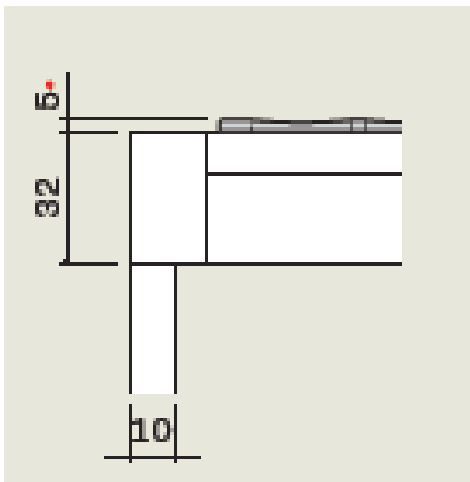

*NOTE: Maximum projection of the cover centered on post at front

RIALTO 02P : Wall Mounted and if multiple Coupled on width side.

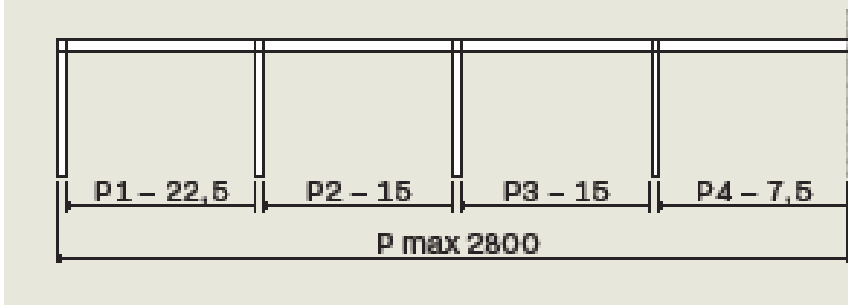
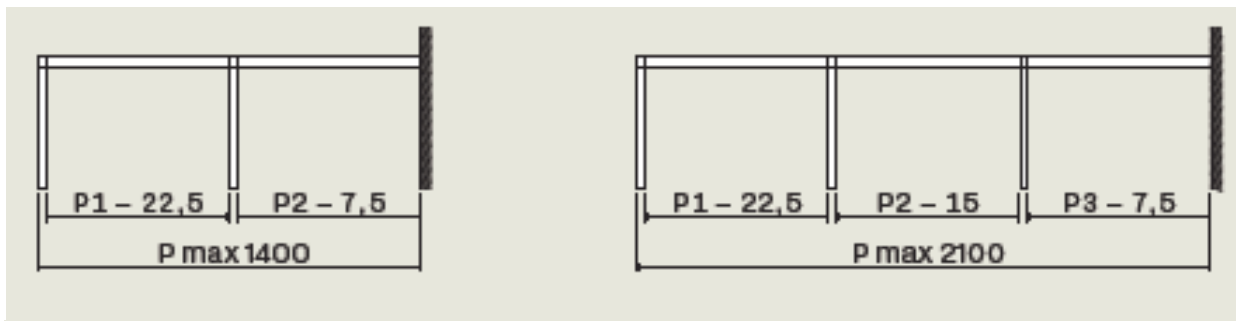
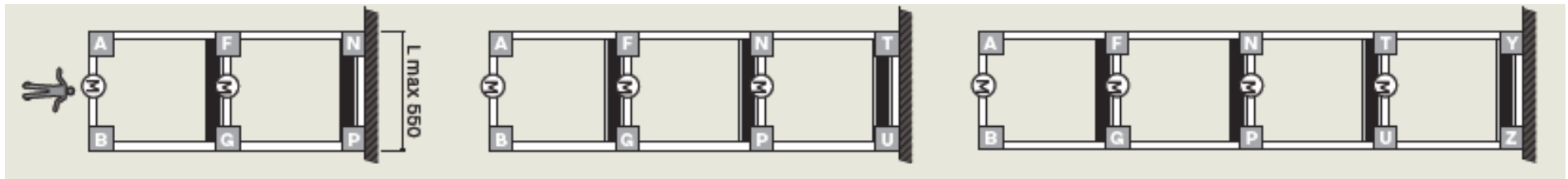

Note: Raso screens not available with RIALTO model.

RIALTO 02P : Wall Mounted con't.

SIDE VIEW

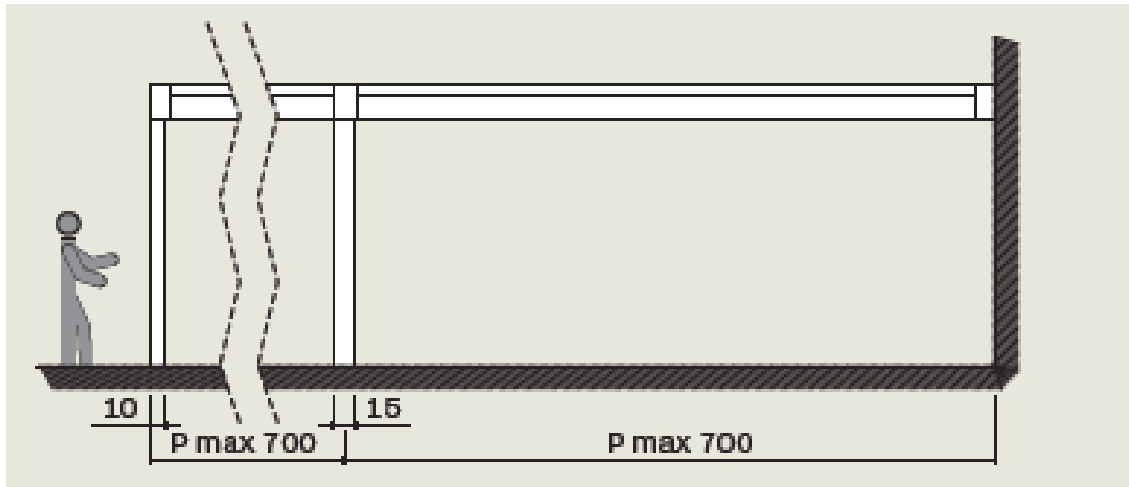

FRONT VIEW

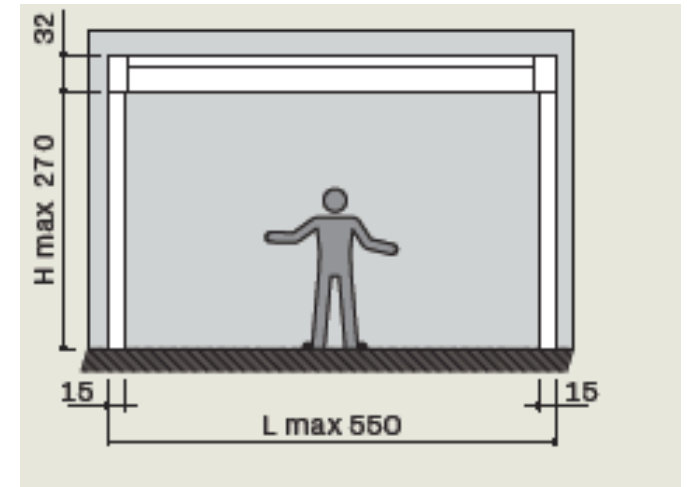

*NOTE: Maximum projection of the cover centered on post

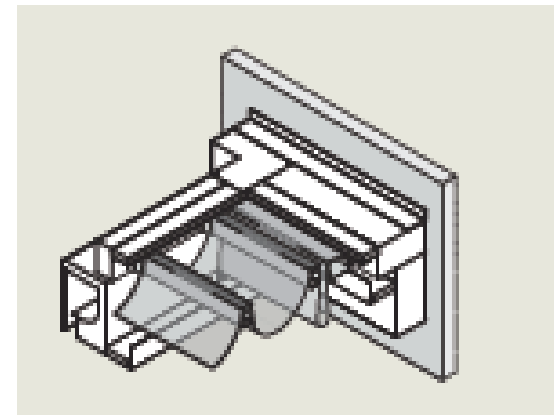
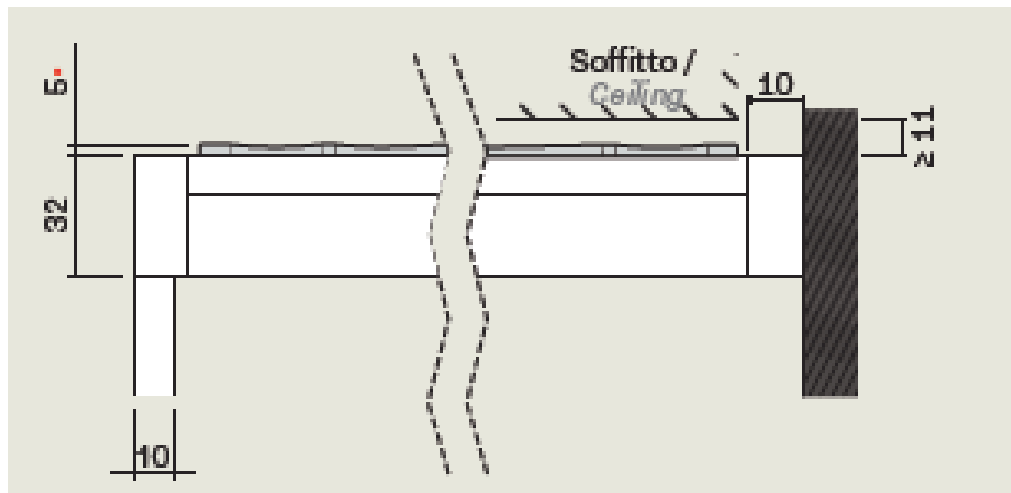

*NOTE: Maximum projection of the cover centered on post at front

RIALTO 03P : Wall Mounted and if multiple Coupled on Projection side.

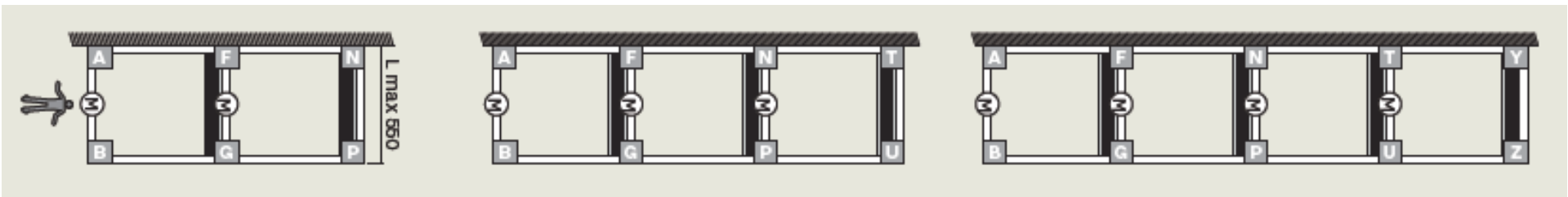

Note:

Drainage capability is reduced on this version due to one side being at the wall.

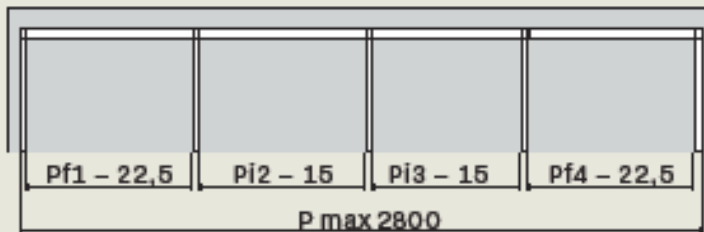
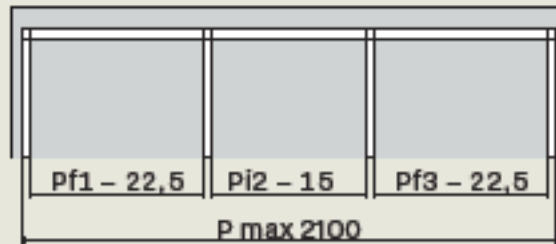
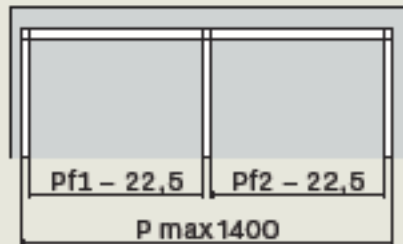

Note: Raso screens not available with RIALTO model.

RIALTO 03P : Wall Mounted con't.

SIDE VIEW

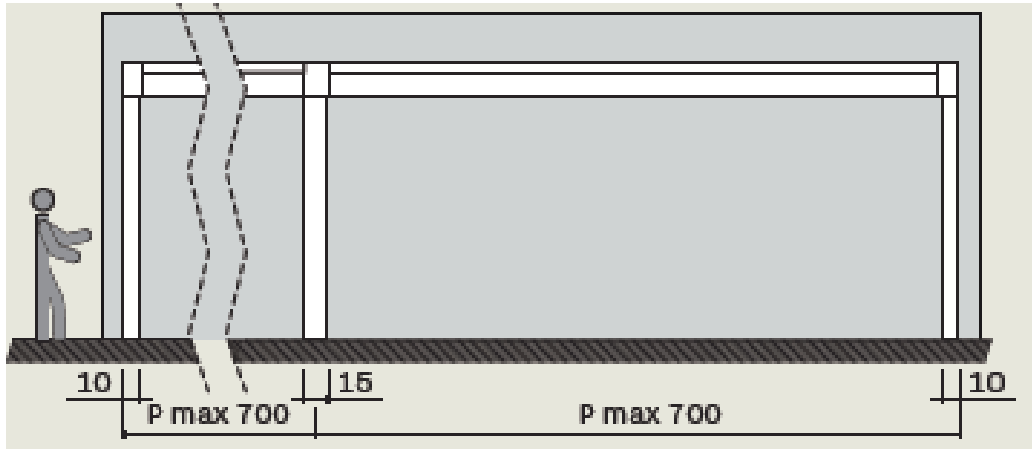

FRONT VIEW

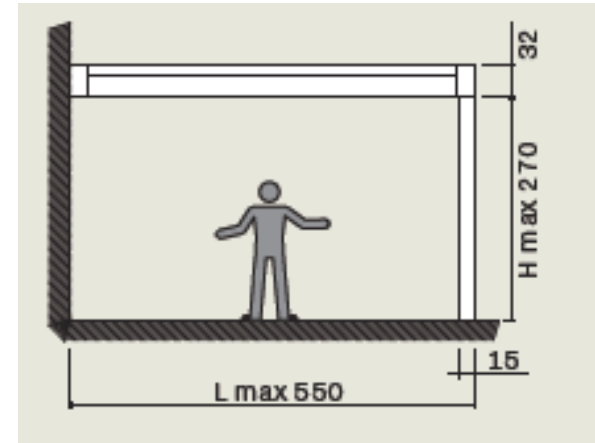

*NOTE: Maximum projection of the cover centered on post

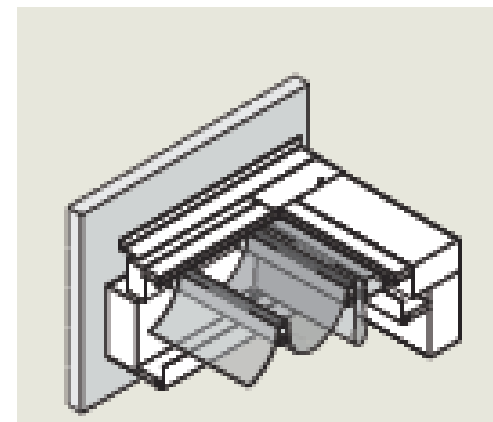
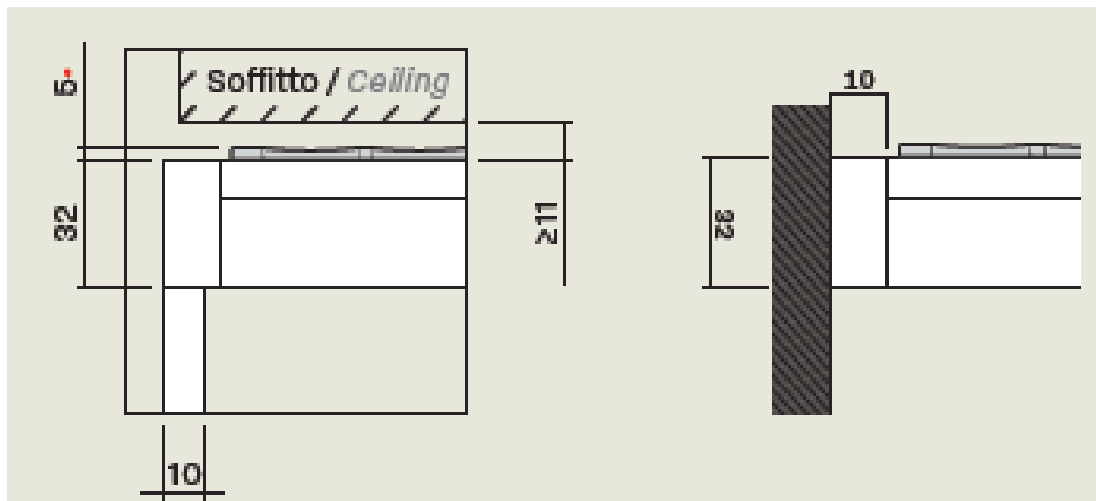

*NOTE: Maximum projection of the cover centered on post at front

RIALTO technical Details.

Supporting Box Profile Projection side

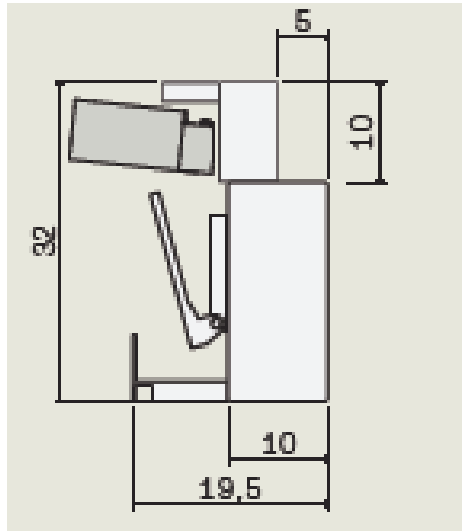

Supporting Box Profile Width side

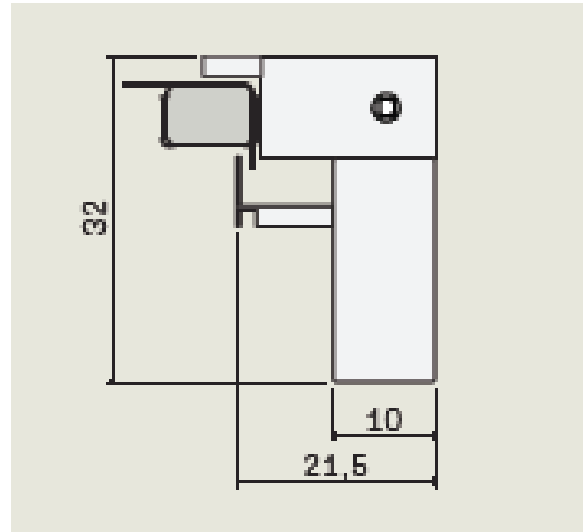

Intermediate Supporting Profile

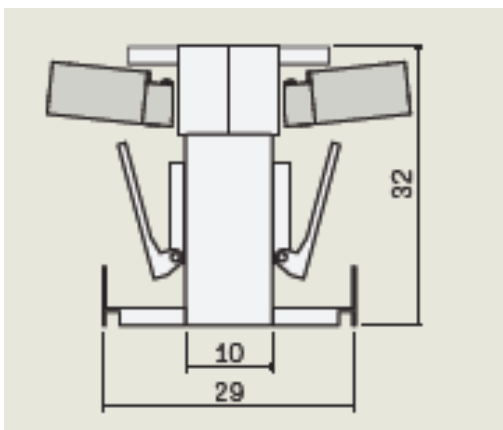

Post Profile

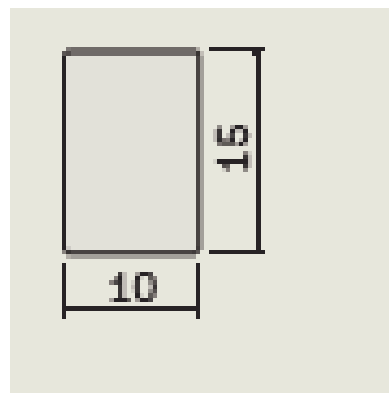

Wall Mounting With Profile

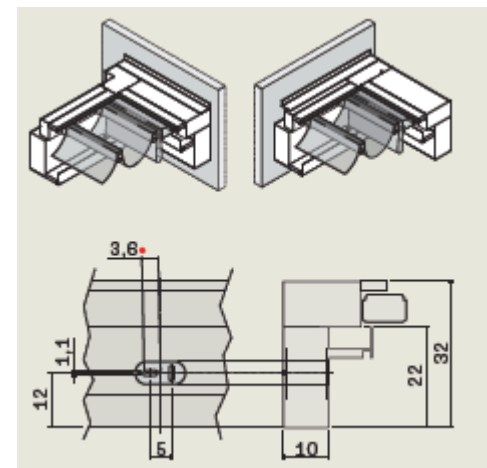

RIALTO More Technical Details.

Tilting Gutter

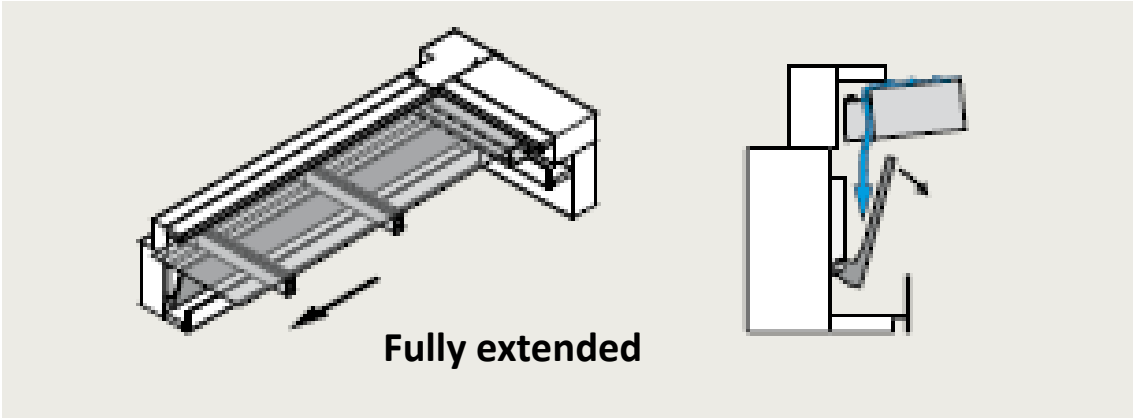
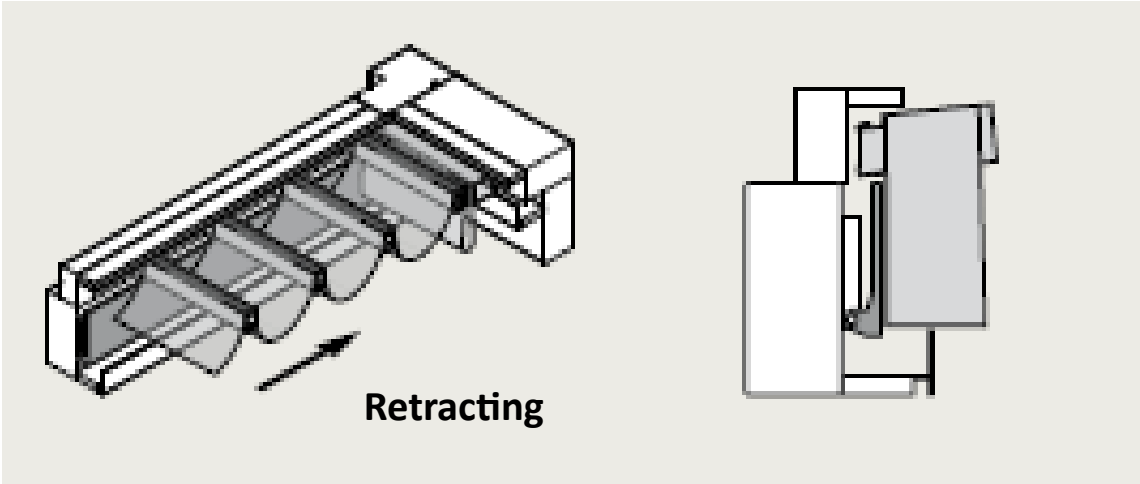

RIALTO Post options.

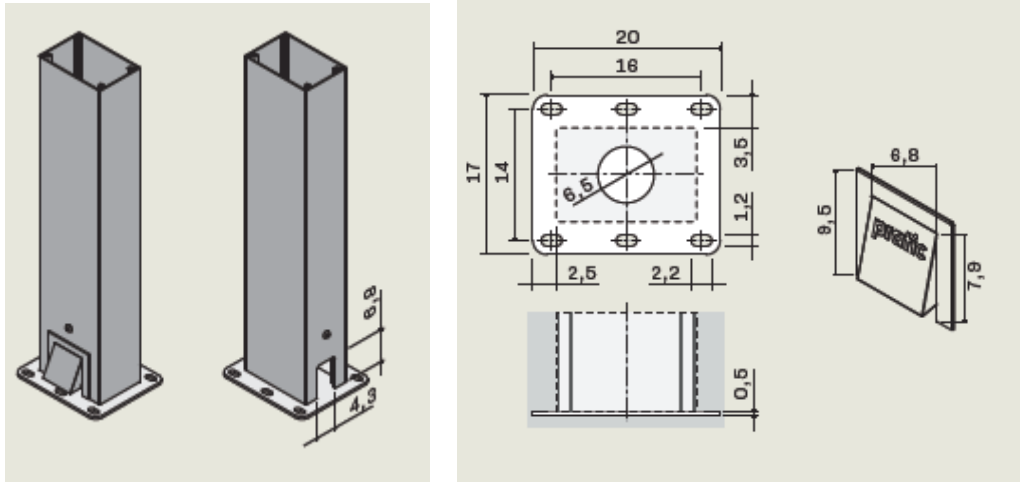

STANDARD POST & FOOT PLATE

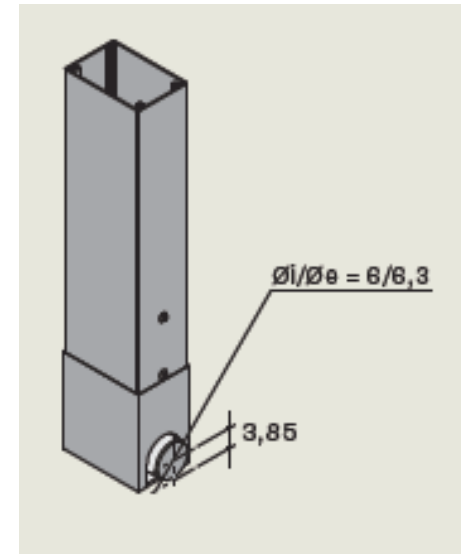

TELESCOPING FOOT PLATE

POST HEIGHTS:

Standard under gutter 90" (230 cm)

Up to 98" no additional cost. (250 cm)

Above 98" extra cost per post.

RIALTO: Max height posts 106" (270 cm)

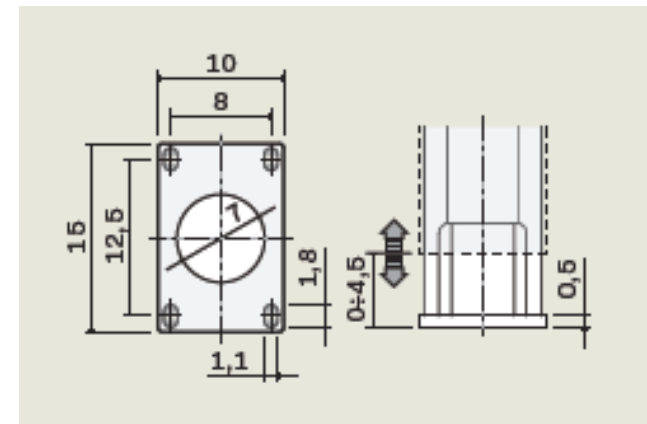

RIALTO Post drainage options.

Front drainage option

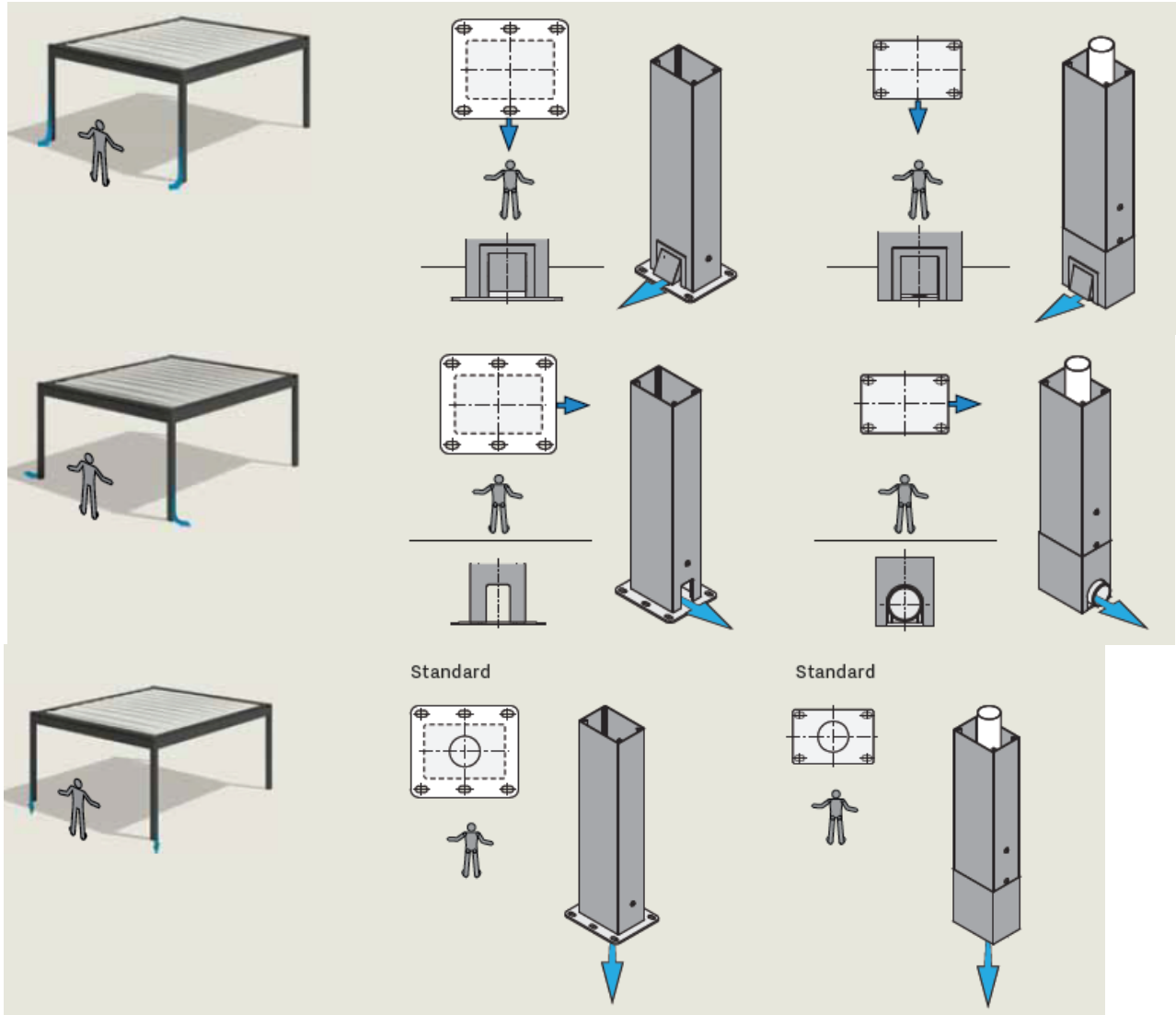

Down drainage option

NOTE: The RIALTO fabric is arched on the top so a drainage points are needed on each side of each module. Two drainage points per module is minimum (More is better).

Post Drainage Points NOMO & RIALTO

It is best to have the unit drain out of every post on the Nomo and Rialto units.

Minimum two (2) posts must be used for drainage per “Module” or section. The drainage points must also be on opposite side of each other where water flows off the curved top. In other words , one drainage point per side that the water flows off the top fabric. Below are some examples of configurations with minimum drainage.

Example #1: If you have one unit you can have two drainage points at the front or back. You can also have it staggered as long as one is on each side of the fabric as water drains off the top.

Example #2: If you have three (3) side by side Nomo or Rialto units with 4 posts at front and 4 post at back, you will need six (6) drainage points total. Four on either front or back and then two more as per below.

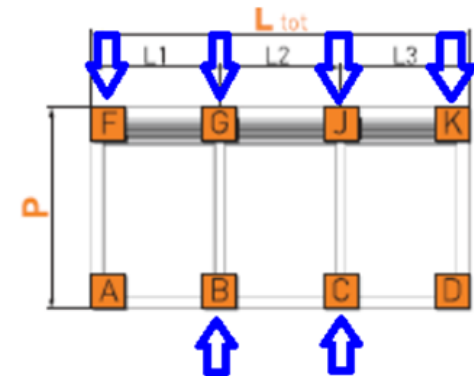
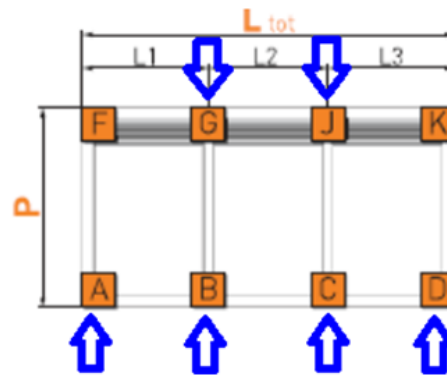
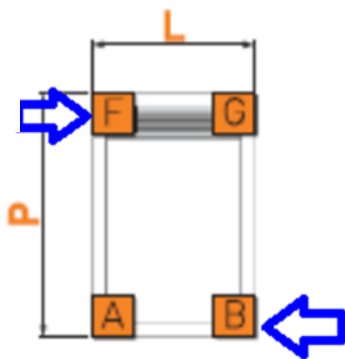
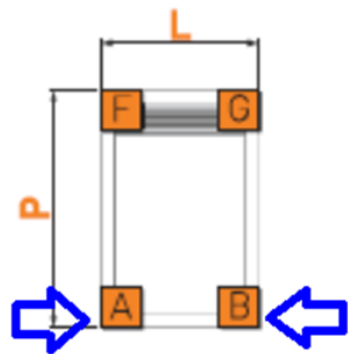

01L / 03L		01P / 03P - 2M		
Module 1	# of Ribs	Module 1	Module 2	# of Ribs
P		P	P	
186,8	2	177,4	176,8	2
229,8	3	220,4	219,8	3
272,9	4	263,5	262,9	4
315,9	5	306,5	305,9	5
359,0	6	349,6	349,0	6
402,0	7	392,6	392,0	7
445,1	8	435,7	435,1	8
488,1	9	478,7	478,1	9
531,2	10	521,8	521,2	10
574,2	11	564,8	564,2	11
617,3	12	607,9	607,3	12
660,3	13	650,9	650,3	13
700,0	14	694,0	693,4	14
		700,0	700,0	15

NOMO

Rib & dimensional table.

of ribs to left represent # of intermediary ribs. Add one back and one front rib also. Total # of fabric bays is one (1) less than number of total ribs including front and back.

01P / 03P - 3M				02P / 03P - 4M			
Module 1	Module 2	Module 3	# of Ribs	Module 1	Module 2/3	Module 4	# of Ribs
P	P	P		P	P	P	
177,4	167,4	176,8	2	177,4	167,4	176,8	2
220,4	210,4	219,8	3	220,4	210,4	219,8	3
263,5	253,5	262,9	4	263,5	253,5	262,9	4
306,5	296,5	305,9	5	306,5	296,5	305,9	5
349,6	339,6	349,0	6	349,6	339,6	349,0	6
392,6	382,6	392,0	7	392,6	382,6	392,0	7
435,7	425,7	435,1	8	435,7	425,7	435,1	8
478,7	468,7	478,1	9	478,7	468,7	478,1	9
521,8	511,8	521,2	10	521,8	511,8	521,2	10
564,8	554,8	564,2	11	564,8	554,8	564,2	11
607,9	597,9	607,3	12	607,9	597,9	607,3	12
650,9	640,9	650,3	13	650,9	640,9	650,3	13
694,0	684,0	693,4	14	694,0	684,0	693,4	14
700,0	700,0	700,0	15	700,0	700,0	700,0	15

02L	
Module 1	# of Ribs
P	
184,3	2
227,3	3
270,4	4
313,4	5
356,5	6
399,5	7
442,6	8
485,6	9
528,7	10
571,7	11
614,8	12
657,8	13
700,0	14

02P - 2M		
Module 1	Module 2	# of Ribs
P	P	
177,4	174,3	2
220,4	217,3	3
263,5	260,4	4
306,5	303,4	5
349,6	346,5	6
392,6	389,5	7
435,7	432,6	8
478,7	475,6	9
521,8	518,7	10
564,8	561,7	11
607,9	604,8	12
650,9	647,8	13
694,0	690,9	14
700,0	700,0	15

NOMO

Rib & dimensional table con't.

of ribs to left represent # of intermediary ribs. Add one back and one front rib also.
Total # of fabric bays is one (1) less than number of total ribs including front and back.

02P - 3M			
Module 1	Module 2	Module 3	# of Ribs
P	P	P	
177,4	167,4	174,3	2
220,4	210,4	217,3	3
263,5	253,5	260,4	4
306,5	296,5	303,4	5
349,6	339,6	346,5	6
392,6	382,6	389,5	7
435,7	425,7	432,6	8
478,7	468,7	475,6	9
521,8	511,8	518,7	10
564,8	554,8	561,7	11
607,9	597,9	604,8	12
650,9	640,9	647,8	13
694,0	684,0	690,9	14
700,0	700,0	700,0	15

02P - 4M			
Module 1	Module 2/3	Module 4	# of Ribs
P	P	P	
177,4	167,4	174,3	2
220,4	210,4	217,3	3
263,5	253,5	260,4	4
306,5	296,5	303,4	5
349,6	339,6	346,5	6
392,6	382,6	389,5	7
435,7	425,7	432,6	8
478,7	468,7	475,6	9
521,8	511,8	518,7	10
564,8	554,8	561,7	11
607,9	597,9	604,8	12
650,9	640,9	647,8	13
694,0	684,0	690,9	14
700,0	700,0	700,0	15

01L / 02L / 03L		01P / 02P / 03P - 2M		
Module 1	# of Ribs	Module 1	Module 2	# of Ribs
P		P	P	
181,9	2	175,0	175,8	2
224,9	3	218,0	218,8	3
268,0	4	261,1	261,9	4
311,0	5	304,1	304,9	5
354,1	6	347,2	348,0	6
397,1	7	390,2	391,0	7
440,2	8	433,3	434,1	8
483,2	9	476,3	477,1	9
526,3	10	519,4	520,2	10
569,3	11	562,4	563,2	11
612,4	12	605,5	606,3	12
655,4	13	648,5	649,3	13
698,5	14	691,6	692,4	14
700,0	15	700,0	700,0	15

RIALTO

Rib & dimensional table.

of ribs to left represent # of intermediary ribs. Add one back and one front rib also.

Total # of fabric bays is one (1) less than number of total ribs including

01P / 02P / 03P - 3M				01P / 02P / 03P - 3M			
Module 1	Module 2	Module 3	# of Ribs	Module 1	Module 2/3	Module 4	# of Ribs
P	P	P		P	P	P	
175,0	168,9	175,8	2	175,0	168,9	175,8	2
218,0	211,9	218,8	3	218,0	211,9	218,8	3
261,1	255,0	261,9	4	261,1	255,0	261,9	4
304,1	298,0	304,9	5	304,1	298,0	304,9	5
347,2	341,1	348,0	6	347,2	341,1	348,0	6
390,2	384,1	391,0	7	390,2	384,1	391,0	7
433,3	427,2	434,1	8	433,3	427,2	434,1	8
476,3	470,2	477,1	9	476,3	470,2	477,1	9
519,4	513,3	520,2	10	519,4	513,3	520,2	10
562,4	556,3	563,2	11	562,4	556,3	563,2	11
605,5	599,4	606,3	12	605,5	599,4	606,3	12
648,5	642,4	649,3	13	648,5	642,4	649,3	13
691,6	685,5	692,4	14	691,6	685,5	692,4	14
700,0	700,0	700,0	15	700,0	700,0	700,0	15

NOMO & RIALTO Dimensions con't.

# of Ribs	Dimension +/- 1 cm	
	Without Undercover	With Undercover
2	38	39,5
3	43	45,0
4	48	50,5
5	53	56,0
6	58	61,5
7	63	67,0
8	68	72,5
9	73	78,0
10	78	83,5
11	83	89,0
12	88	94,5
13	93	100,0
14	98	105,5
15	103	111,0

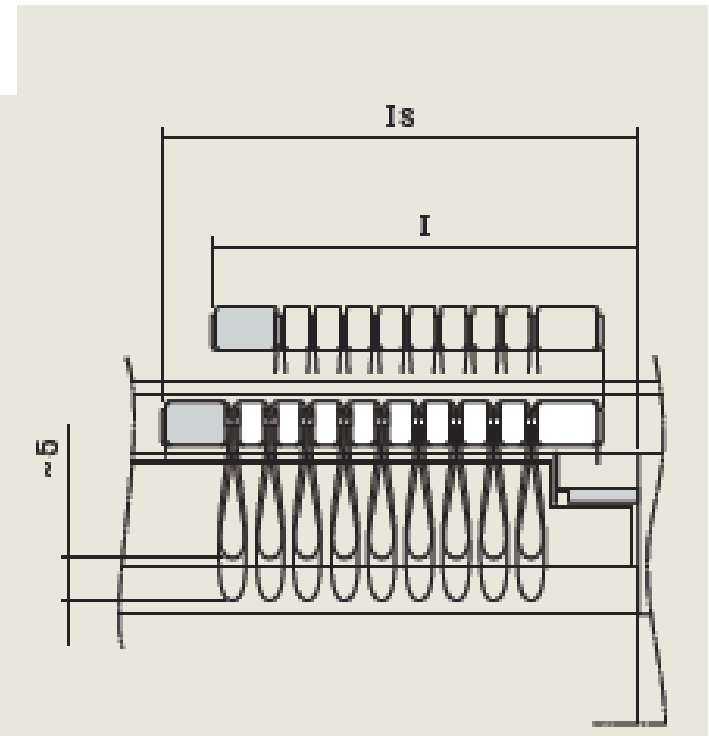

of ribs above represent # of intermediary ribs. Add one back and one front rib also.

Total # of fabric bays is one (1) less than number of total ribs including front and back.

LEGEND:

I = Fabric fold without undercover

Is = Fabric fold with undercover added

Note: Undercover fabric will hang 5 cm lower when folded

RIALTO Post Location and Orientation Diagram.

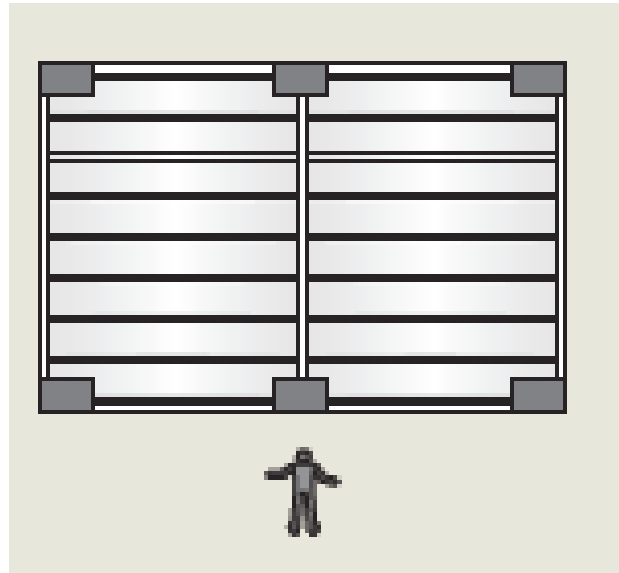
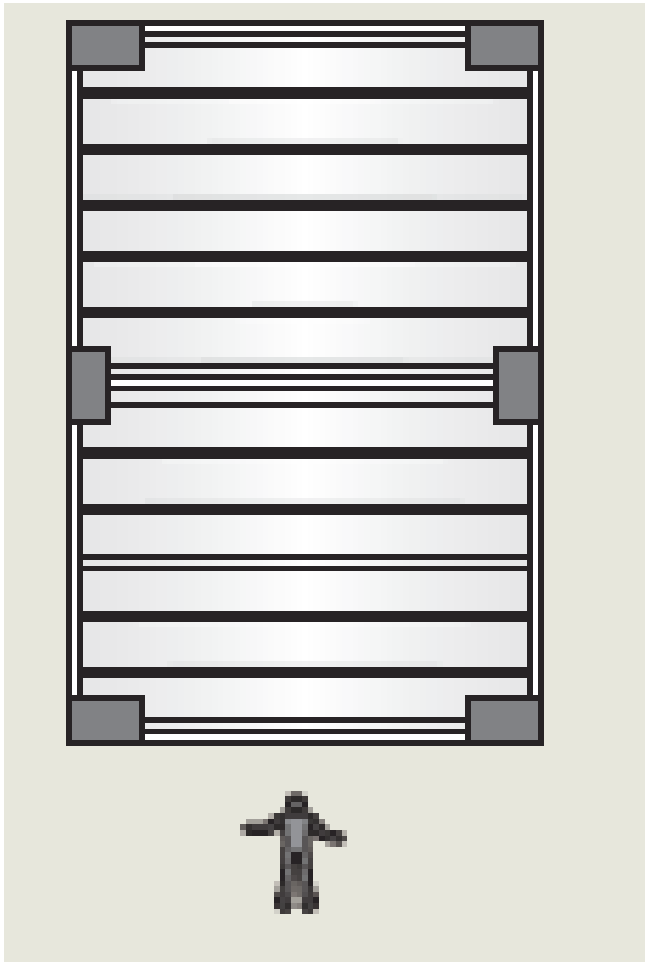

NOMO & RIALTO FABRIC DISCLAIMER.



Creases in the retracted cover.

Note:

NOMO & RIALTO fabric covers when retracted may present some natural creases due to the curvature of the ribs. These phenomena cannot be subject to dispute since they cannot be avoided and they do not influence the proper functioning of the structure (See picture to the Left).



Note:

NOMO & RIALTO units with LED lighting will have wires heat sealed into the cover for the electrical connection of the LED lights. These wires must be positioned so they are visible under the fabric so they don't interfere with proper water drainage of the cover (See picture to the Left).

NOMO & RIALTO Options:

RASO ROLL DOWN ZIPPER SCREENS For NOMO only

Paired Raso with additional upright

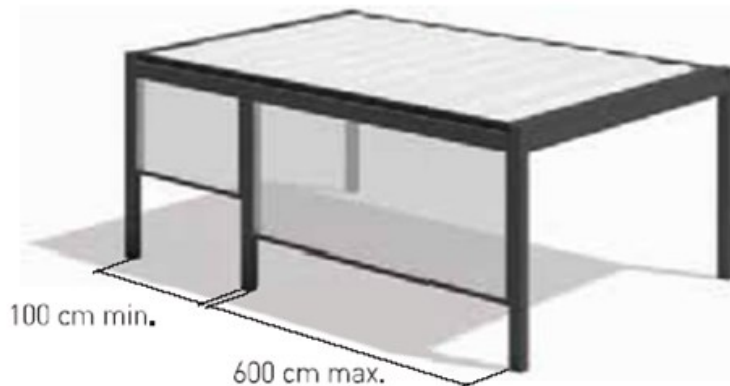

Note:

Maximum available Raso screen width will depend on fabric type. An additional intermediary post can be added to cover the side with multiple screens.

Optional roll down screens can be added to the NOMO model only.

Note: Raso screens are NOT available with the “Rialto” model.

The screens are available with mesh fabrics and also vinyl with windows (single or double). Please inquire on window size specifications needed.

Available Fabric are:

Tempotest Para Acrylic fabric (Colors from range)

Mosquito Mesh 50% open (Grey & Black)

Soltis 86 mesh (Colors from range)

Soltis 92 mesh (Colors from range)

Ferrari 502/602 with windows (Colors from range)

Max widths available:

Mosquito Mesh: 14' 6" wide x 10' high

Soltis 86 & 92: 19'6" wide (6 m)

Para & Ferrari 502/602: 19' 6" wide (6m)

Ferrari 502/602 with windows: 13' wide (4 m)

NOTE: If NOMO projection is wider than the maximum allowable screen width above, an intermediary post has to be added at extra cost and two screens must be made in its place. Even if you want to wall mount the NOMO, you still will need post in rear to accommodate the Raso screens.



The NOMO model can be fitted with roll down RASO zipper screens for extra weather or sun protection on all sides. This optional screen system can be ordered with either mesh fabric, acrylic, or vinyl fabric and clear "film" windows for keeping moderate weather at bay during the winter months or rain during spring and summer months. If you only need sun protection on the sides or desire to keep mosquitos and pesky bugs at bay, our mesh fabrics will be fine.

Raso screens with windows

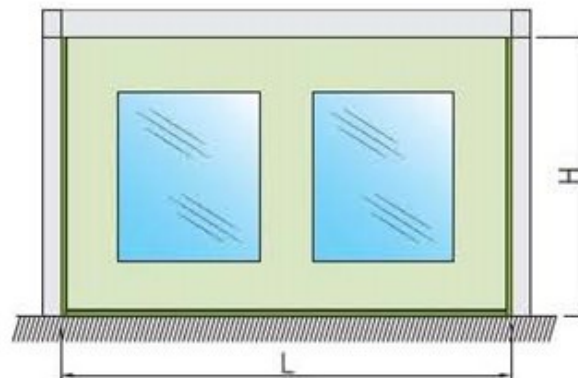

Minimum border width around screen perimeter must be at least 25 cm (10") when using Ferrari with windows (See illustration above)

Raso zipper screens with mesh fabric

RASO Screens con't

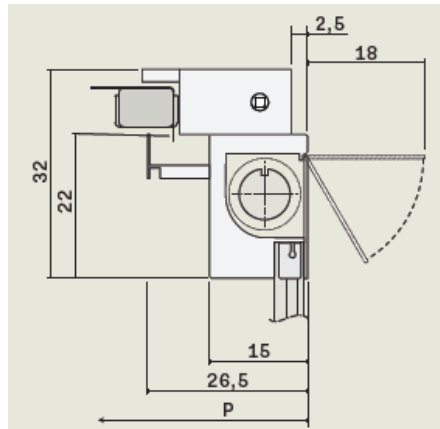
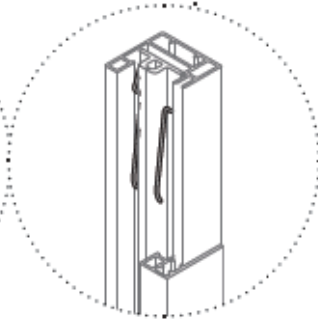
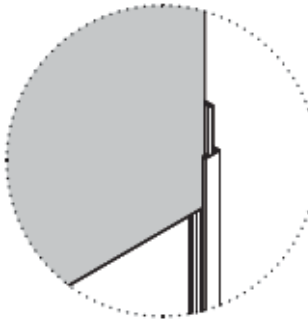
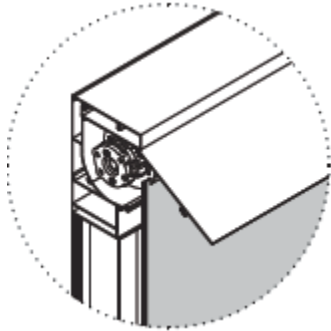
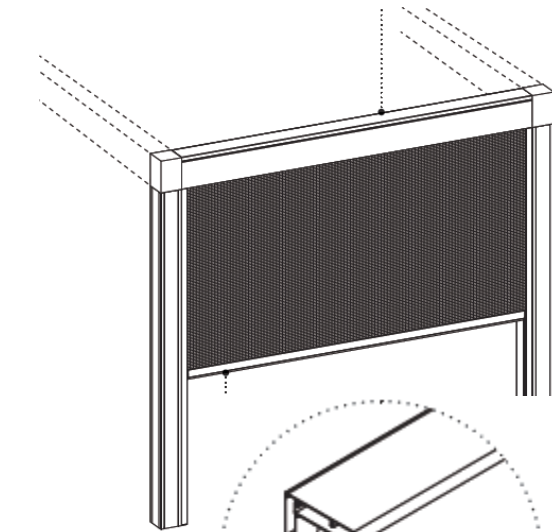

supporting profile with built-in Raso

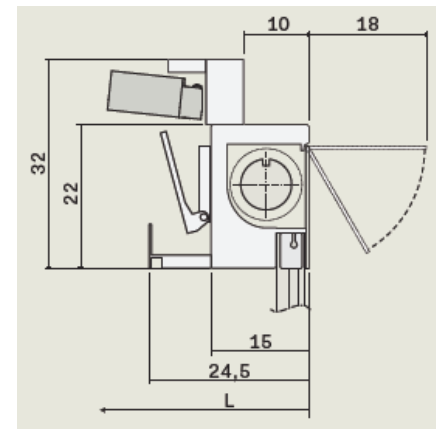

Zip guide profile

Front profile

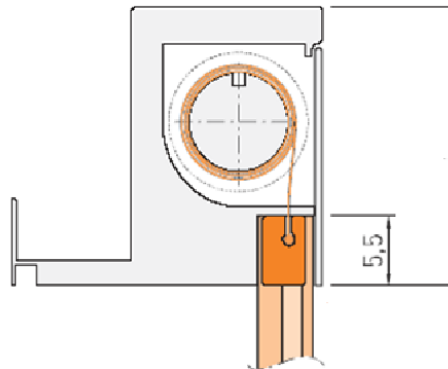

Post profile + Raso guide + compensator

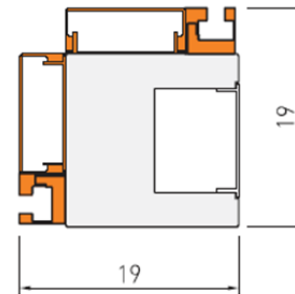
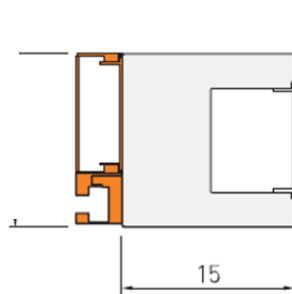
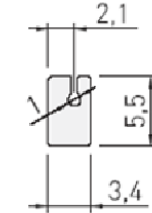
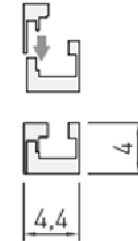

Optional Gasket at bottom of hem bar.

NOMO posts with Raso Track and compensation profile added

UNDERCOVERS NOMO & RIALTO

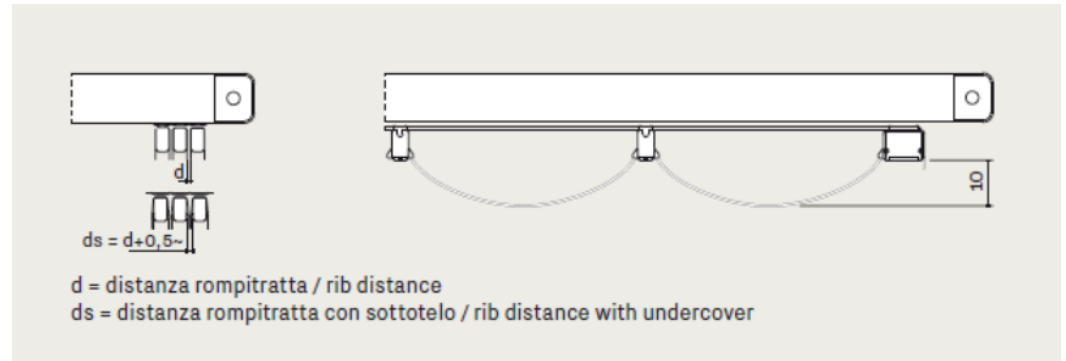

To create a nice atmosphere with the NOMO and RIALTO pergola, it is possible to apply an undercover between the ribs covering up the vinyl fabric (Available three fabric colors below).

Note: NOMO and RIALTO undercovers should be ordered with the Pergola. If ordered later, please inquire.



Color: 6006



Color: 6007



Color: 6008

PERIMETER & RIB LED LIGHTING

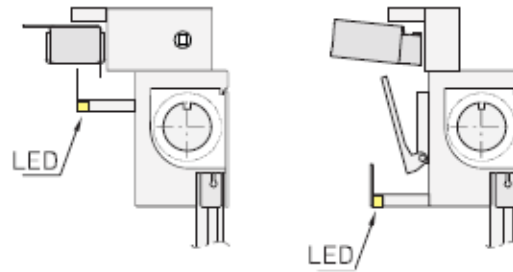

LED / WHITE only or RGB in-line lighting

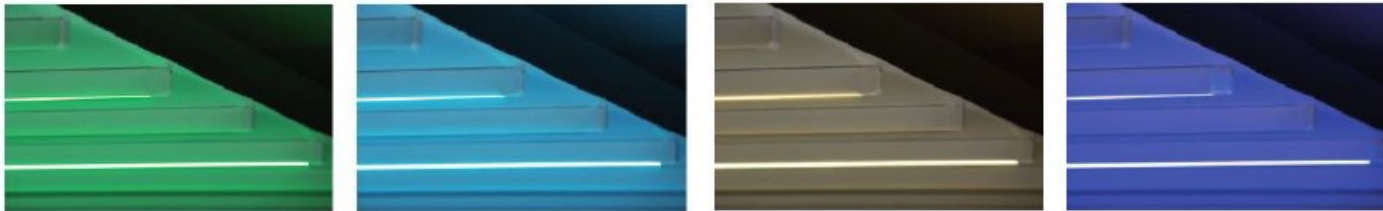

REMOTE CONTROLLED



LED / WHITE only
Or, RGB Perimeter lighting

LED In-Line configurations (NOMO & RIALTO)

LED Line position: Please refer to the number of ribs for the pergola module you desire. Maximum two (2) Led kits can be configured with each “module”. A two module unit can have two LED kits. LED kits must be ordered at time of Pergola manufacturing.

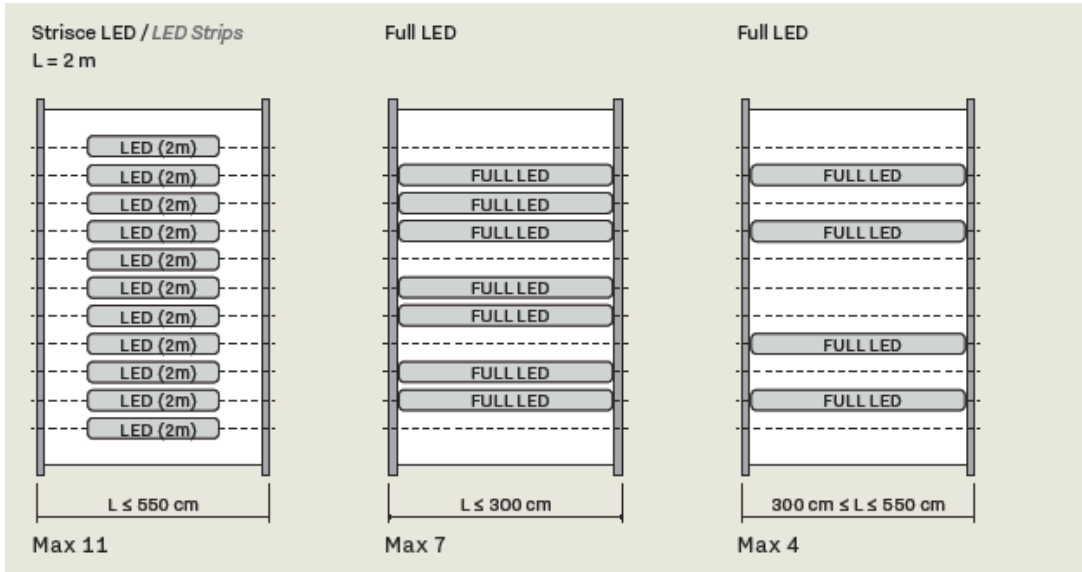

- Power Supply: 24 volts
- Light Output 420 Lumen/m
- Electrical use 14,4 W/m
- Maximum LED is 22 meter / kit

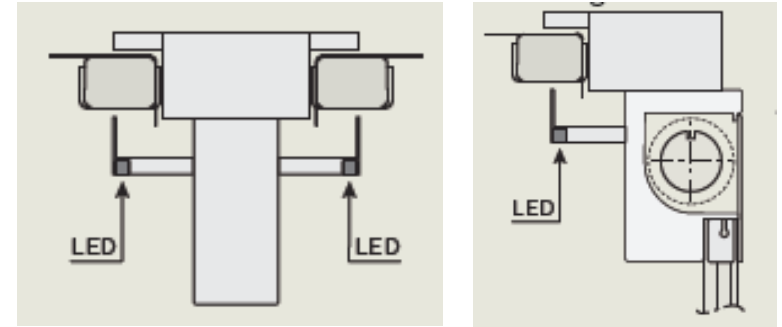

LED Perimeter configurations (NOMO & RIALTO)

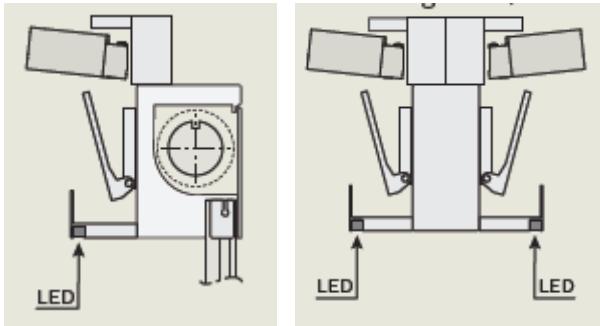

Perimeter Upright

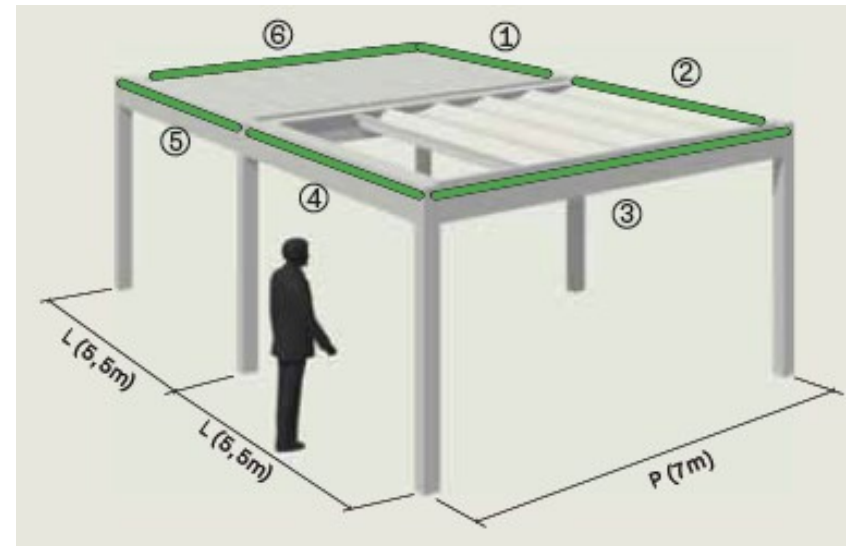

NOMO & RIALTO: More Options



RASO Side zipper screens (Nomo model only)

Undercovers

Mesh fabric or with windows

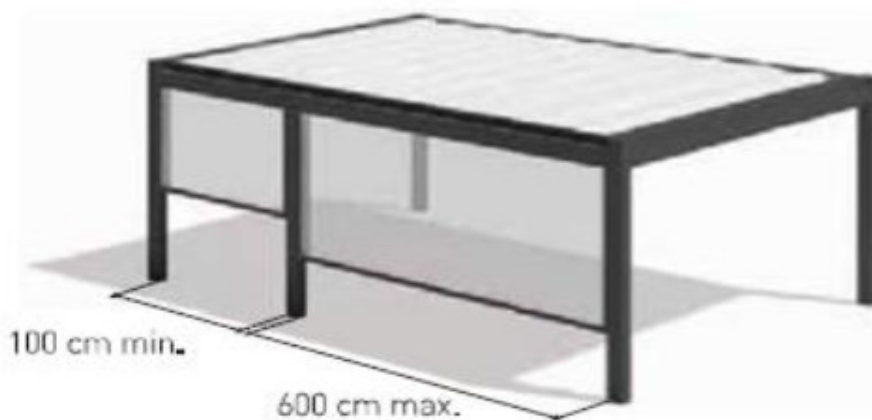
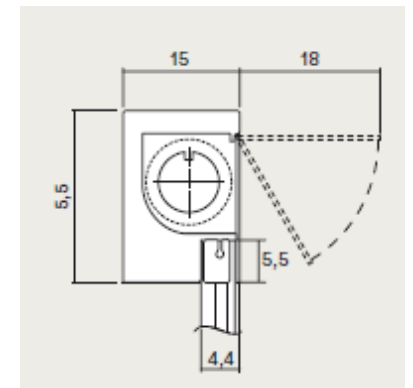
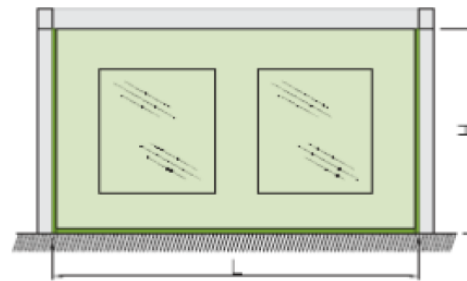

Post profile + Raso guide + compensator

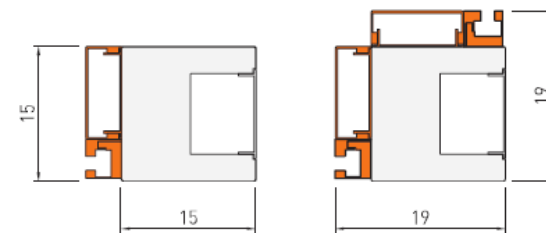

STANDARD FRAME COLORS FOR NOMO & RIALTO PERGOLA :

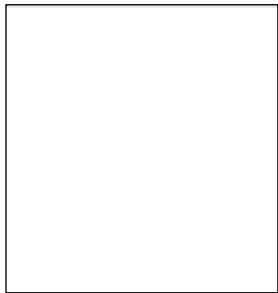

WHITE Gloss
Ral 9010

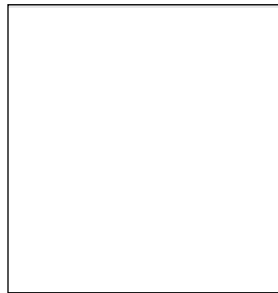

WHITE SAND
Coarse Ral 9016



IVORY SAND
Ral 1013 Coarse



IVORY / SEMI
Gloss Ral 1013

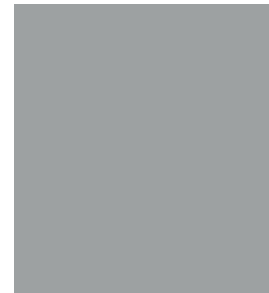

GREY SAND
Gloss Ral 9006



BRIGHT ALUM
Matt Ral 9006

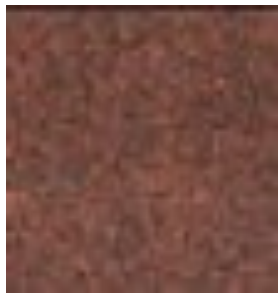

CORTEN
Coarse



IRON GREY
Coarse

OPTIONAL

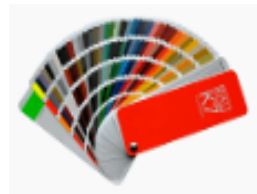

FULL RAL COLOR
RANGE / EXTRA
COST

NOTE: These eight (8) colors are “super durables” which offer better durability compared with standard polyesters powders.



NOTE: ACTUAL FRAME COLOR MAY VARY FROM DIGITAL IMAGES

PERGOLA STANDARD FABRIC COLORS

602 FLEX LIGHT CLASSIC / OPAQUE COLORS



602-8503-98"

White 602

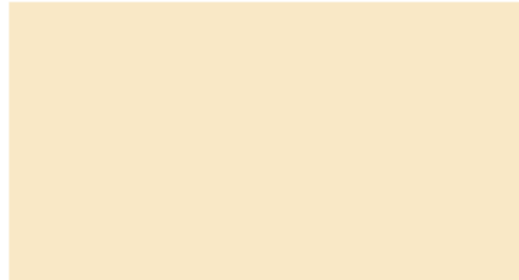

602-50020-98"

Cream 602

The Preconstraint 602 fabric from Ferrari offers excellent dimensional stability with minimal stretching and exceptional dirt resistance thanks to a PVDF topcoat on both sides. The fabric is therefore perfect for use on retractable Pergola® roof awnings. The fabric is 22.1 oz/sq yard with a Glossy finish. The two standard opaque colors above are the most commonly used and is standard on all Pergola® awnings. The two above colors are opaque and do not allow light to go through the fabric. Fabrics are Fire Retardant and certificate is available.

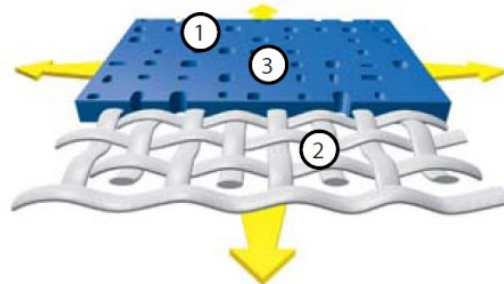

OPTIONAL PERGOLA & SCREEN FABRIC COLORS

502 PROOF SOLTIS / OPAQUE SATIN FINISH COLORS

The Preconstraint 502 fabric from Ferrari also offers excellent dimensional stability with minimal stretching and exceptional dirt resistance thanks to a PVDF topcoat on both sides. The fabric is therefore perfect for use on retractable Pergola® roof awnings. The fabric is 16.8 oz/sq. yard with a satin finish. Fabrics are fire retardant and certificate is available.



satin finish



Serge Ferrari

Soltis
Horizon 86

Serge Ferrari
14 % Open Screen Mesh

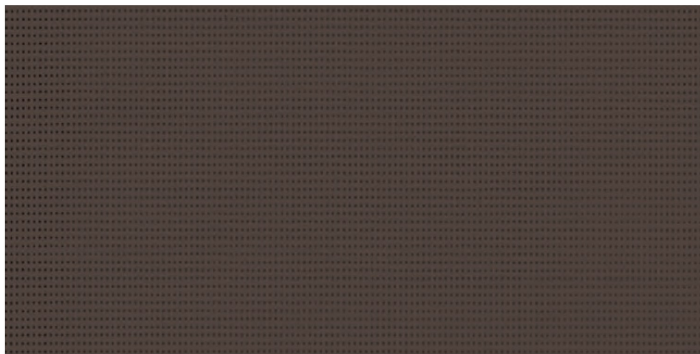

Raso Screen



86-2043
Bronze

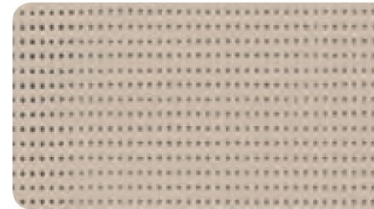

86 – 2135
Sandy Beige

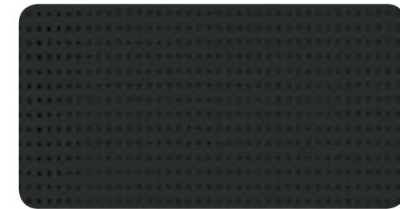

86 – 2053
Black

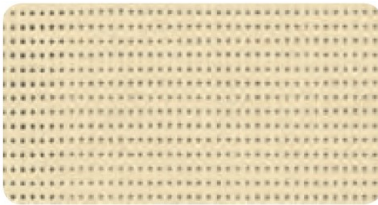

86 – 2175
Champagne

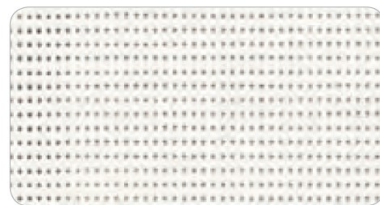

86 – 2044
White

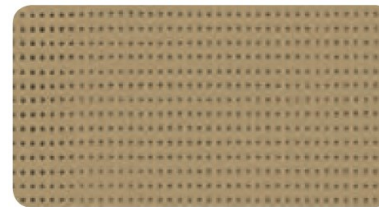

86 – 2012
Pepper

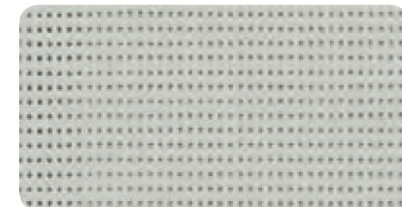

86 – 2171
Boulder

■ Technical properties

Openess factor	14%
Weight	380 g/m ² — 11.2 oz/sqyd
Thickness	0.45 mm — 450 microns
Width	177 cm - 267 cm — 69.7 in. - 105.1 in.

Superior elongation and tear resistance

No deformation during processing and use

Superior aesthetic and mechanical durability

Smooth finish easy to clean, space saving, easy rolling

MOTORIZATION & AUTOMATION

ALTUS®



Note:

Opera and Vision Louvered systems uses a different Linak motor and remote.

The Sunair PERGOLA® program features SOMFY RTS motor with an integrated radio receiver that allows you to operate the awning or screen by remote control with a wall mounted or hand held remote and by a smart phone device.

With a simple click of a button on your remote, the awning or shade will extend, retract , lower or raise automatically.



1 through 16 channel wall mounted and hand held remotes are available



OUR FABRIC ROOF PERGOLA® MOTORS

Sunair uses Somfy motors and controls for their Pergola awnings in the following range

Altus 535/550 Series: Nomo, Rialto ,



Note: Motor type 535/550 used will depend on the size and projection of the unit.

All Somfy Motors are UL and CSA Recognized

- All SOMFY motors are UL Recognized and can be found under the following file numbers:

E60495, E60888, E63714



	550
Torque	50 Nm
Nominal Voltage	
Rated Current	2.1A
Speed	14 rpm

Type of power cable

RTS
120V AC / 60Hz
3 conductor cable

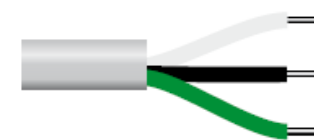

white = neutral

black = hot

green = ground



Radio Technology Somfy

Radio Technology Somfy® (RTS) allows wireless radio control of motorized applications via the RTS family of controls.

Screen motor for RASO zipper screens



SCREEN MOTORS:

The screens are available with the 525 altus SOMFY motor and also the 525 Maestria Obstacle detection motor. These motors are tubular 110 volt motors and are integrated into the Raso roller tube like a normal screen motor. Electrical wiring for the Raso screens is integrated within the gutter system and posts and all electrical connections are pre-wired within the Pergola system to one central connection point for all the electrical options and motors. The Maestria obstacle detection motor prevents fabric damage resulting from screen bunching and slipping from the guides. The motor senses and distinguishes between an actual obstacle and wind, even wind gusts, so it doesn't stop unnecessarily, resulting in fewer service calls and end user peace of mind.

Type of cable

RTS
120 V / 60 Hz
3 conductor cable

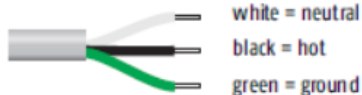

Note: It is recommended to use a multi channel Telis 4 remote to operate multiple screens. The Screen motors use the same RTS technology motor as all Pergola models

Performances

525A2

Torque	25 Nm
Nominal Voltage	
Rated Current	1.6A
Speed	20 rpm
Thermal Protection	
Radio Frequency	433.42 MHz



SOLIRIS RTS 24V KIT Sun & Wind Sensor

The Soliris RTS Sun and Wind Sensor automatically controls your RTS motorized products based on current weather conditions.



ONDEIS® WIREFREE Sun & Rain Sensor

The Rain Sensor is a solar-powered combined rain and sun sensor compatible with Radio Technology Somfy® motorized exterior products, including awnings and screens.

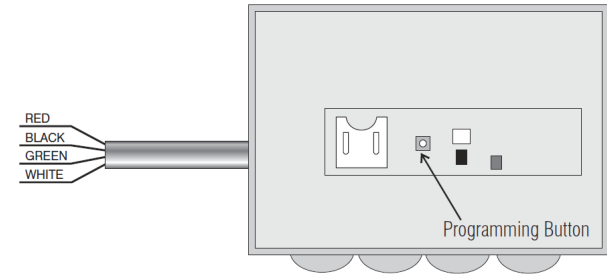

DRY CONTACT INPUT RTS TRANSMITTER

Dry Contact to RTS interface can be used to communicate between home automation or other third party systems like fire alarms to retract screens in an emergency. Can be interfaced with a physical switch.

The Somfy myLink™ is a simple device that turns your smartphone or tablet into a sophisticated remote control for motorized products featuring Radio Technology Somfy®, allowing you to operate them whether you're home or not. Combine all the benefits of Somfy's RTS hand-held remotes and timers in a convenient app.



FAN: Adding a fan to following models:

NOMO, RIALTO, BRERA, VISION, and OPERA

Fan not included and by customer



MULTI MODULE PERGOLAS

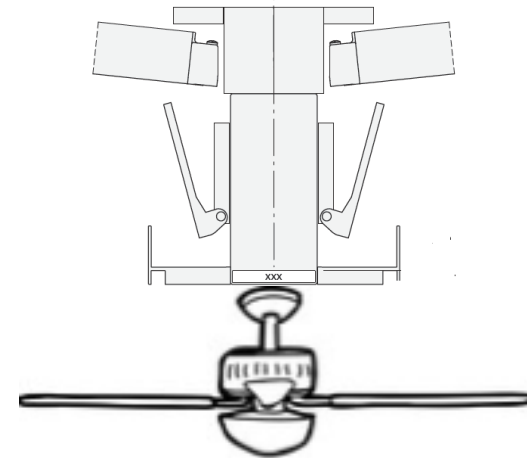
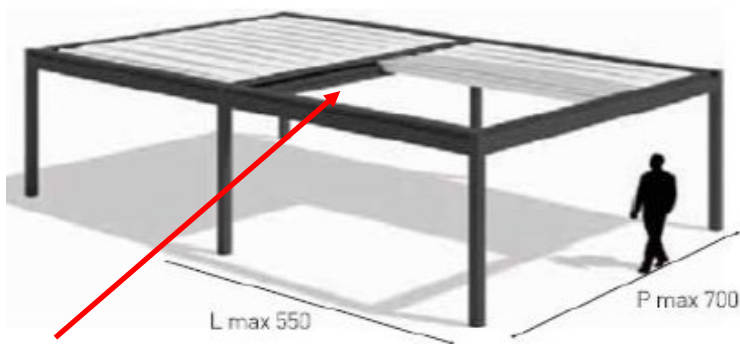

Fan Can be mounted Here in between each module

SINGLE BAY PERGOLAS

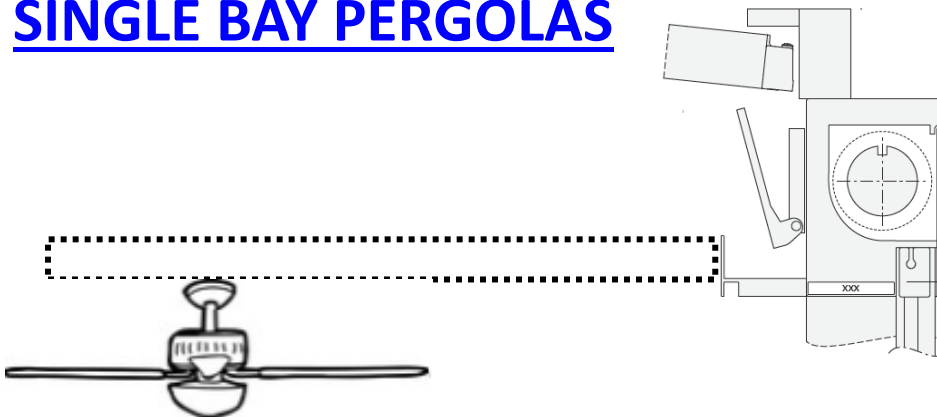

Mount a “Fan Bar” on the width side between gutters

Note: Max unit width 18 ft per module. Fan bar must run along the width of each module and separately wired.

Solaira[®]

COSY
SERIES



HEATERS COSY SERIES 1500 AW Sleek, Low clearance, infrared

Sunair[®] awnings do not specify any particular brand of heaters but we do offer the Solaira brand as a convenience and as “supply” only. As supply only all warranty is per the Manufacturer (Solaira). Please see separate manufacturers installation, use, servicing and warranty documents. Mounting and wiring the heaters on the Pergola units is not included and will be the responsibility of the dealer / customer in the field during installation. Check your local codes for correct wiring instructions. All heaters should be installed by a certified electrician to local state electrical codes. See separate manufacturer’s data sheet and wiring instructions. If you purchase your own heaters, make sure that the heater brand and model you chose can be installed within the pergola unit to code. Aluminum Brackets to install the heaters on the awning are sold separately. Note: Sunair[®] awnings can only make suggestions but will not be responsible or warranty the performance and the effectiveness of the heaters. Check with the manufacturer of the heaters for the recommended number of heaters for your application and best installation position of the heater for best results.

Con’t next page

Solaria Heaters con't

Note: Specifier / Customer must contact Solaira directly for recommended heater number and location.

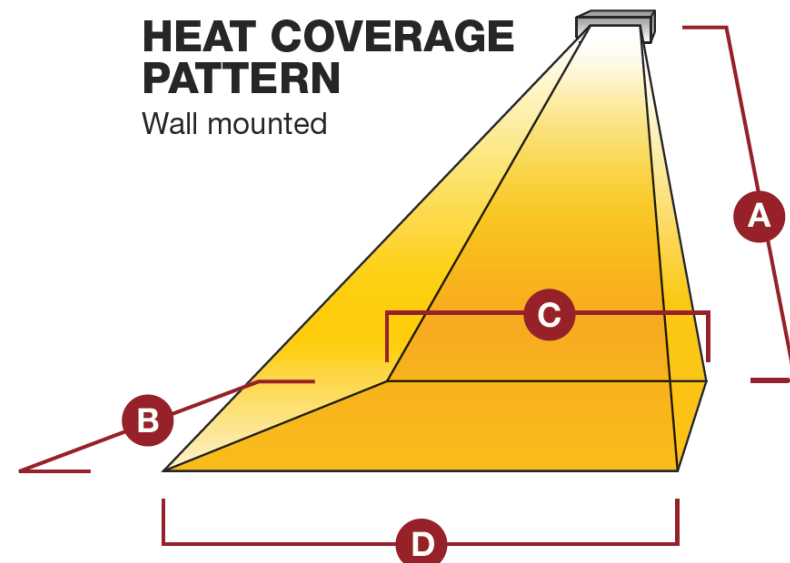

HEAT COVERAGE EXAMPLES

Model	A	B	C	D	Heat Zone*	Heat Density*
SCOSYAW15120 B/W	6'7"	8'	8'	10'	70 SQ FT	18 WATTS/SQ. FT
SCOSYAW15240 B/W	6'7"	8'	8'	10'	70 SQ FT	18 WATTS/SQ. FT

* Heat Zone and actual heat density will vary based on mounting height and angle of heater (Overhead mounted heat zones will be different then this guide). Please use this as a guideline only and contact Solaira for a more detailed specifier guide.

* Heat Zone and actual heat density will vary based on mounting height and angle of heater (Overhead mounted zones will be different than this guide). Please use this as a guideline only and contact Solaira for a more detailed specifier guide.

Con't next page

Solaria COZY Series Heaters con't

240 VOLT: 1.5Kw 208 - 240 V

Heater Model Black # SCOSYAW15240B Ral:9005

Heater Model White # SCOSYAW15240W Ral:9010

Controller #SPASCR90

One controller will operate up to 12 heaters

110 VOLT: 1.5Kw 120V

Heater Model Black # SCOSYAW15120B Ral: 9005

Heater Model White # SCOSYAW15120W Ral:9010

Controller #SPASCR90

One controller will operate up to 7 heaters

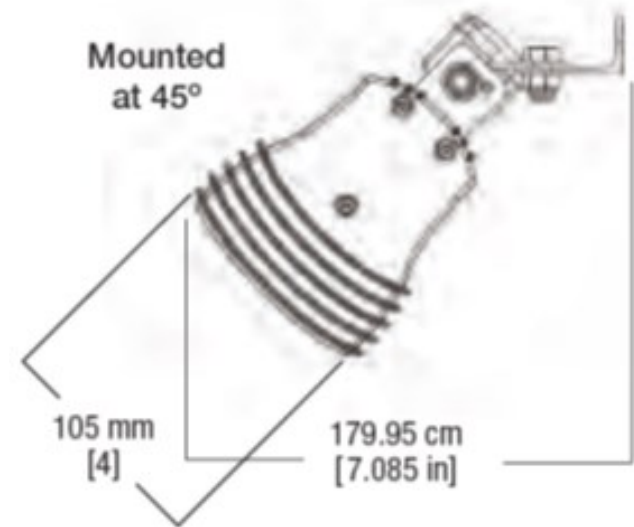

NOTE:

Maximum 7 ea. 110 volt heaters can be used per controller.

Maximum 12 ea. 240 volt heaters can be used per controller.



aura™

INFRARED PATIO HEATER

ADVANCED LOW-LIGHT,
LOW-GLARE CARBON FIBER
EMITTER TECHNOLOGY



IP65 rated
water resistant

AVAILABLE IN TWO MODELS

CF3000 3000W, 240V

CF1500 1500W, 120V

- Adjustable wall and ceiling mounting brackets included*
- Durable extruded aluminum construction
- Virtually maintenance-free
- Instant heat, warm ambient glow
- Safe and odorless



Includes convenient
remote control



Wall and ceiling
brackets included*

AURA CF3000 Carbon 3000W BLACK 208 - 240 VOLT: **Model # CF302408**

AURA CF1500 Carbon 1500W BLACK 120 VOLT: **Model # CF151208**

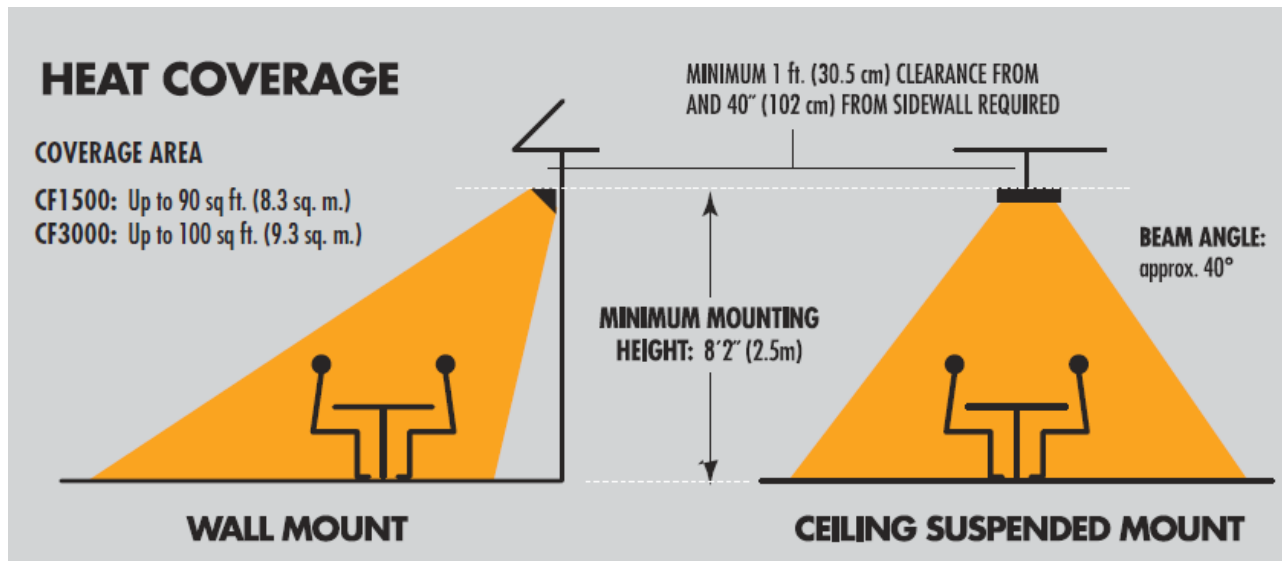

Note:

Specifier / Customer must contact Solaira directly for recommended heater number and location.

CARBON FIBER EMITTER

Aura Carbon Fiber emitter lamps are manufactured with extremely strong and lightweight woven carbon fibers. When energized, the carbon fiber produces a soft, ultra-fast warming medium/short wave infrared, radiant heat.

The image shows a cylindrical carbon fiber emitter lamp. The lamp has a woven carbon fiber exterior and a glowing white light source inside. It is positioned horizontally against a background of orange and black horizontal bands.

*Heat Zone and actual heat density will vary based on mounting height and angle of heater (Overhead mounted zones will be different than this guide). Please use this as a guideline only and contact Solaira for a more detailed specifier guide.

CF1500 WEIGHT: 10lbs (4.5kgs)

CF3000 WEIGHT: 14.3 lbs. (6.5 kg)

ETL Intertek **RoHS** COMPLIANT **IP65**
DUST, RAIN, WATER-JET PROOF
 ÉTANÇHE À LA POUSSIERE, À LA PLUIE ET AUX JETS D'EAU
 POLVO, LLUVIA, PRUEBA DE AGUA-JET

* affixing hardware (screws/bolts/wall anchors not included and to be supplied by installer to suit application)

REMOTE CONTROL

RANGE: UP TO 19.5 ft. (6 m)
INCLUDES ON/OFF BUTTONS WITH 6 HEAT SETTINGS:
33% - 50% - 66%
80% - 88% - 100%

REQUIRES 2x AAA, 1, 5V NOT INCLUDED

The AURA heaters is a more economical heater that simply plugs in to an outlet (110 volt version). This heater does not require a control box. The remote control is included in the price. Simply aim the remote towards the heater and you can custom set the heat from 1 - 6 on heat scale.

SPECIFICATIONS

EXTRUDED ALUMINUM CONSTRUCTION

INCLUDES: CEILING AND WALL MOUNT BRACKETS*, REMOTE CONTROL, 12 ft. (4.87 m) OF cETLus APPROVED, OUTDOOR RATED CABLE

'ON/OFF' SWITCH ON DEVICE

UP & DOWN Glass Walls Options

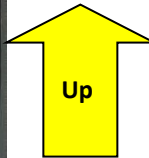

The Up & Down model is made up of two sections, one stationary and one mobile. A simple key is used to lock and release the module. To raise, release window with the key and the spring loaded module will slowly rise on its own.

Standard and custom widths available.

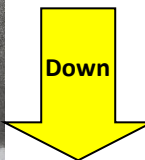

The Up and Down model of our glass window dividers can be customized to match your color scheme or even display your logo! The base aluminum colors are White and Iron Grey colors. Virtually any color and design graphic motifs can be added to the glass to showcase your restaurant's unique style. Other models are also available.



Installations



SET FLOORING :



PRODUCT FEATURES:

- Platform decking designed to be integrated with Bioclimatic Pergolas like Opera, Vision, Brera, Nomo, and Rialto.
- Sits on an existing supported concrete floor.
- Made to fit Pergola awning system.
- Assembled in place.
- Can be fitted with different flooring types.



SET FLOORING cont'

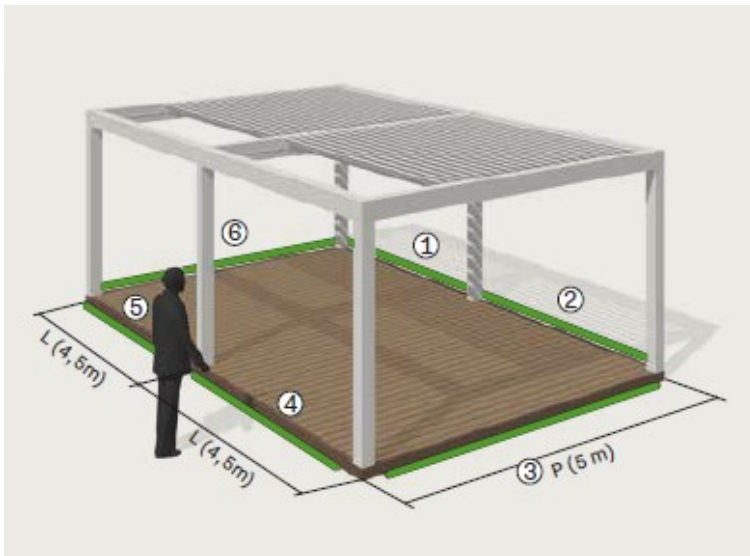

OPTIONAL: LED Lighting added

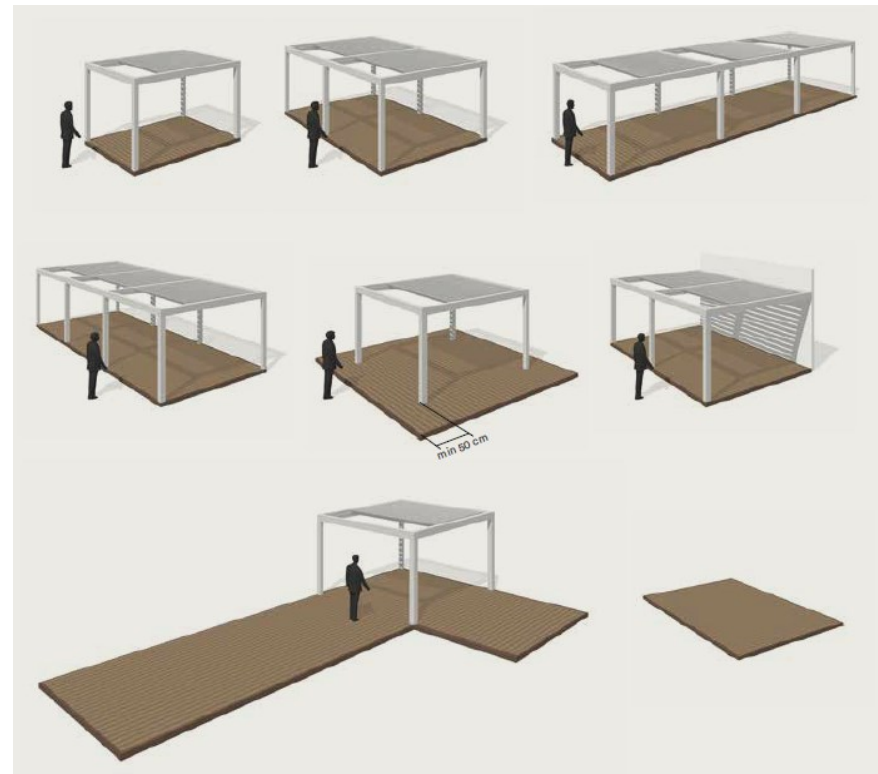

SLIDE GLASS Options for Pergolas:

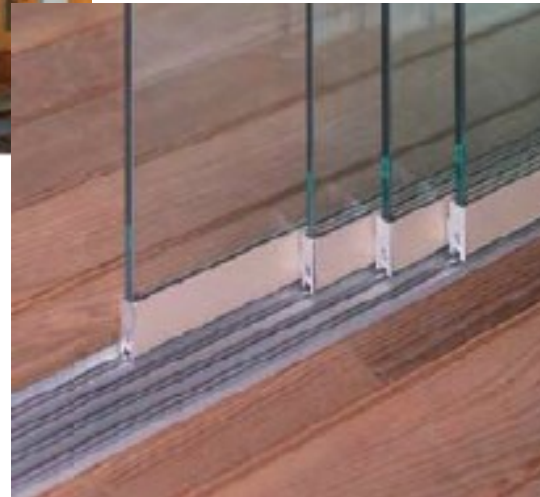

More Installations

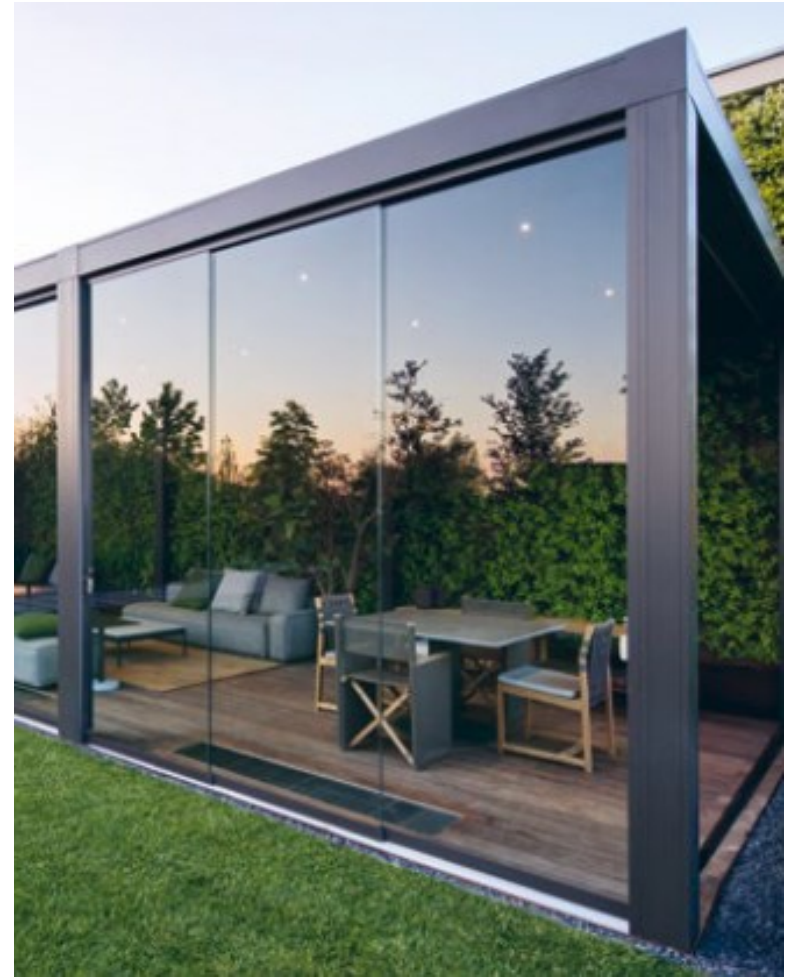

PRODUCT FEATURES:

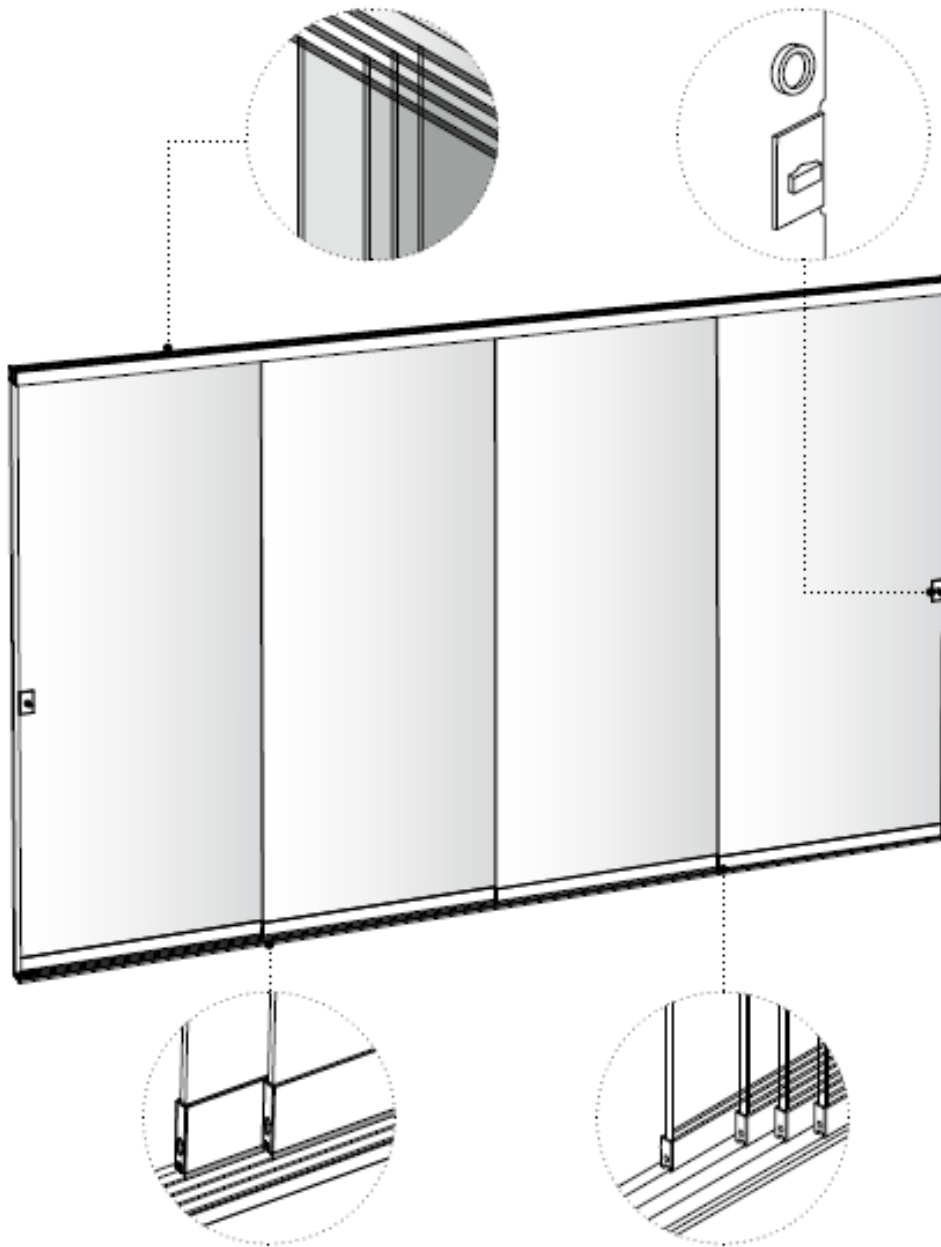

- Glass Panels with aluminum frame.
- Ideal for Bioclimatic Pergola (Rialto, Vision, and Brera S).
- Can be installed along with Raso screens on Nomo, Opera, and Brera P Pergolas also.
- Extruded aluminum Profiles.
- Stainless steel handles.
- Stainless steel trolleys with ball bearings.
- Tempered Glass 10 mm thick weighs 25 Kg. / sq./meter.
- Tempered Glass 12 mm thick weighs 30 Kg. / sq./meter.
- Two, Three, or Four way sections.
- Max Length 700cm depending on number of glass sections.
- 10mm glass available up to 250 cm High doors.
- 12mm glass available from 260 cm to 300 cm high doors.
- Lead time is longer if slide glass is added.

2 ways - 2 doors

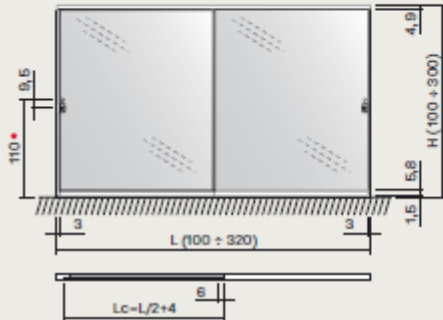

H standard of the closing "S" handle (min. H 25 cm)

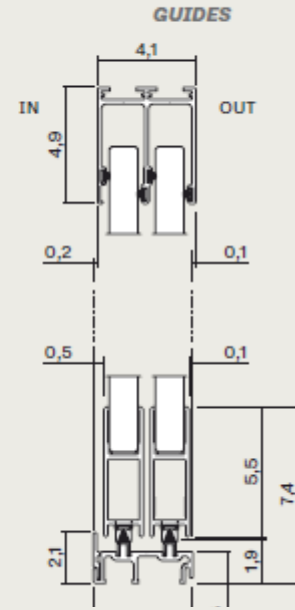
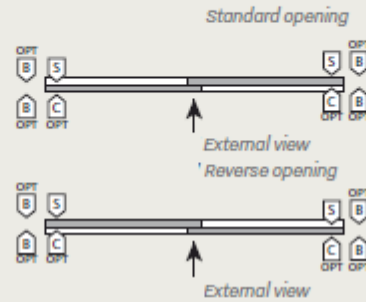

2 ways - 4 doors

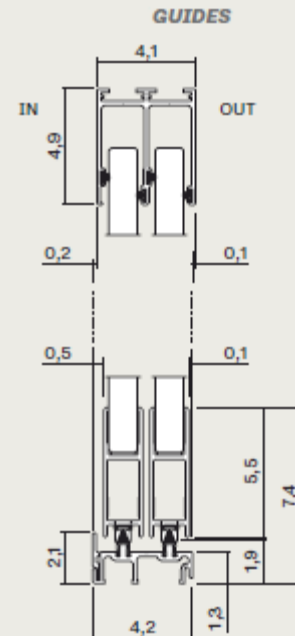
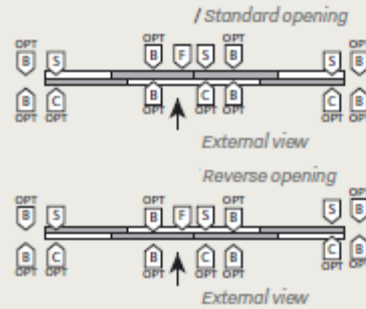
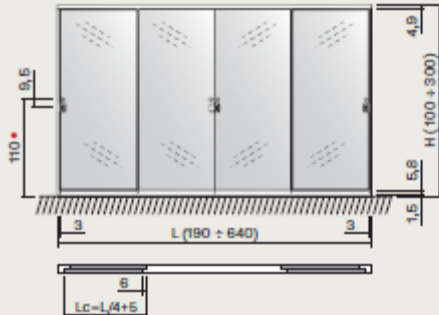

3 ways - 3 doors

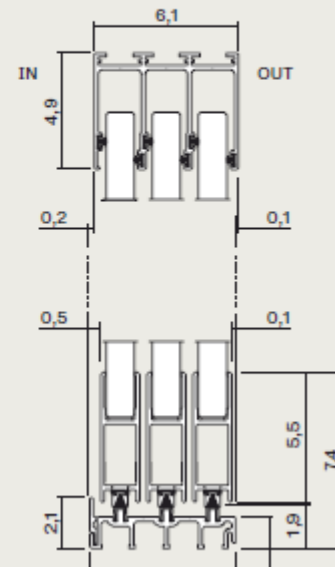
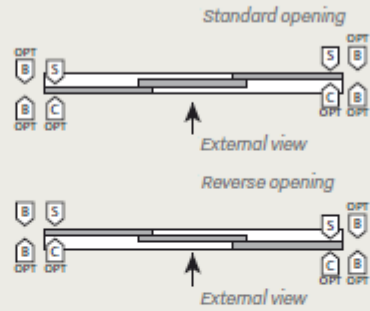
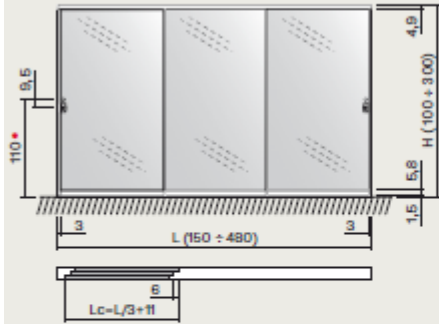

3 ways - 6 doors

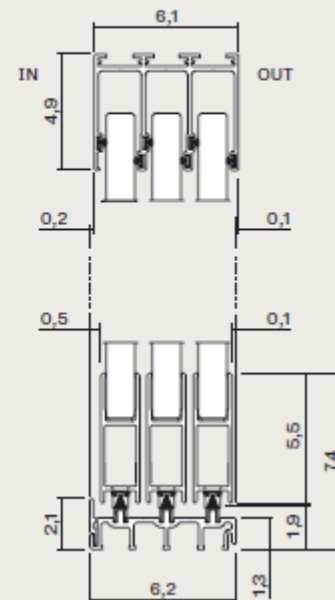
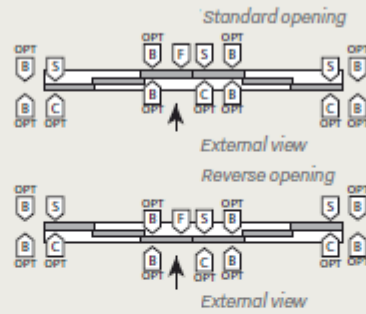
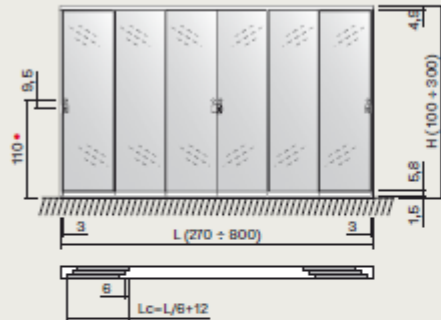

4 ways - 4 doors

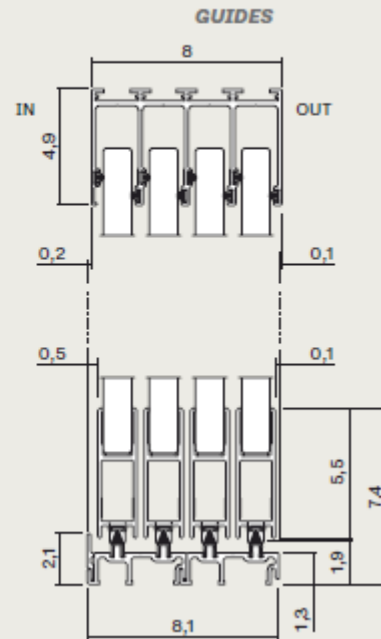
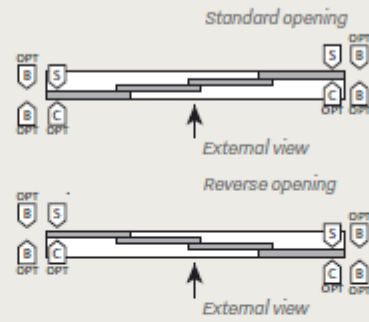
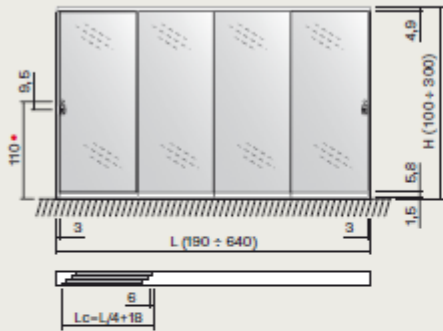

4 ways - 8 doors

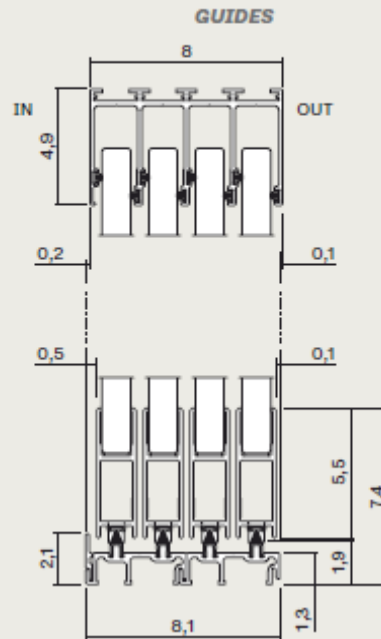
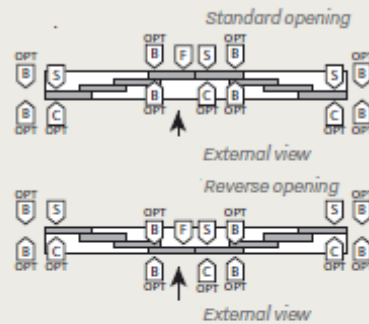
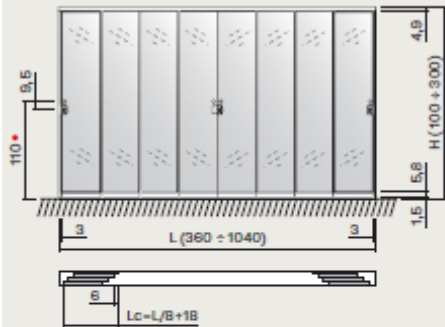

5 ways - 5 doors

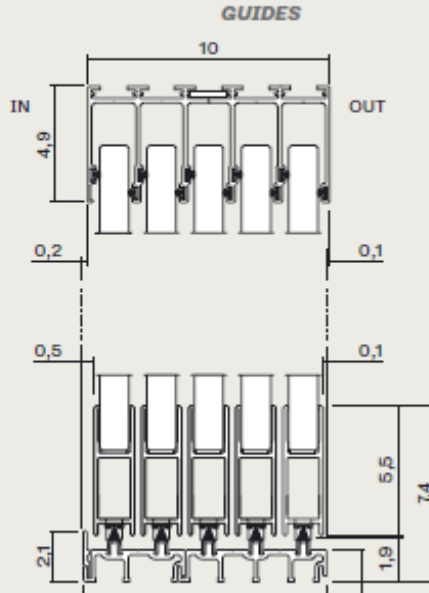
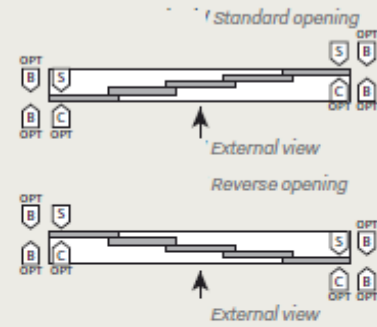
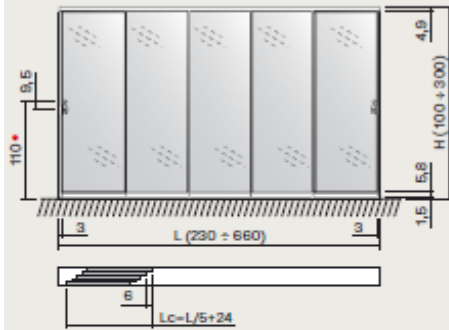

6 ways - 6 doors

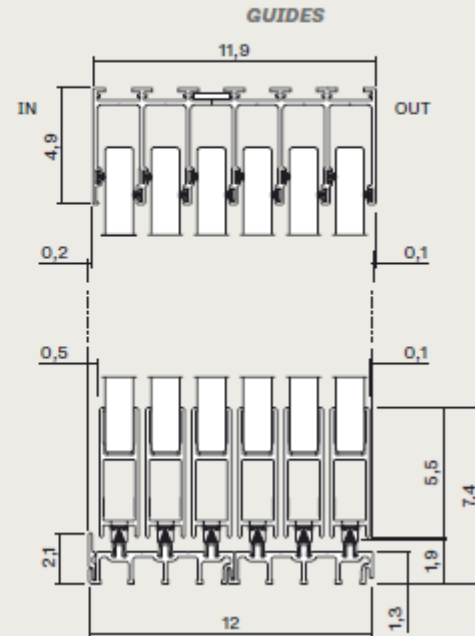
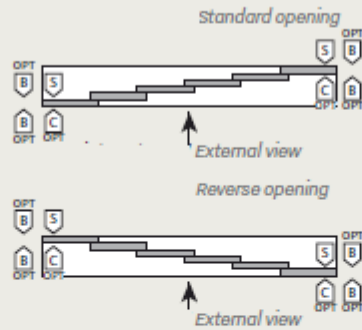
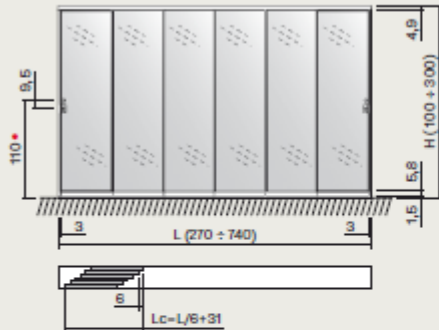

8 ways - 8 doors

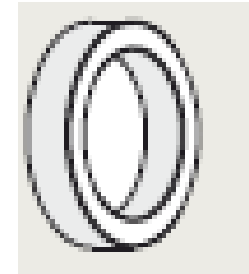
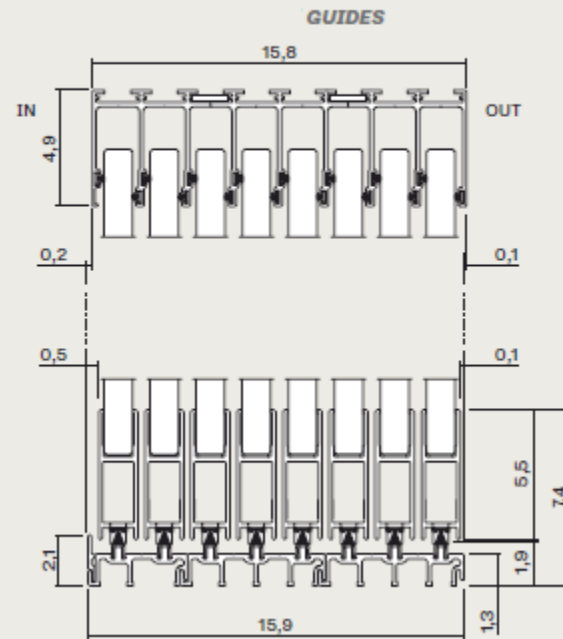
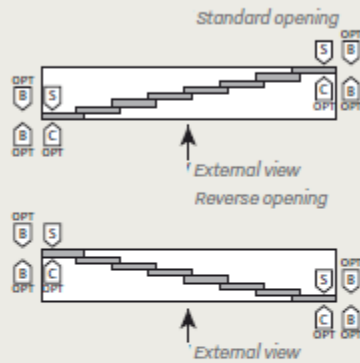
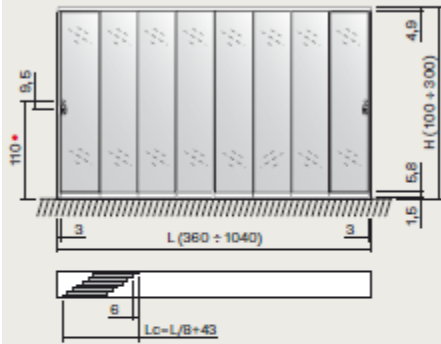

Driving Handle Disk

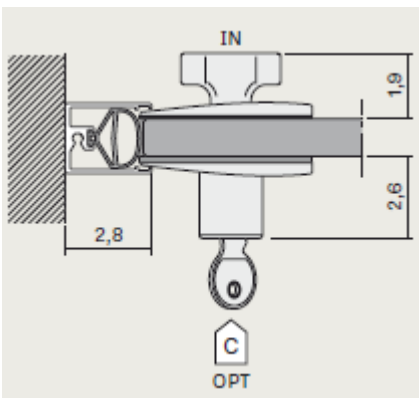

External Key Locks

Not compatible with Raso Screens.

Each Lock has a key.

Door stop on bottom of floor track

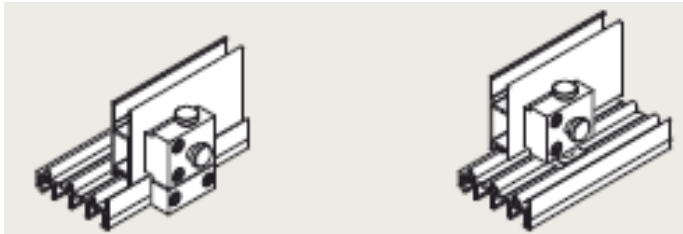

Guide side installation

Installation between Tracks

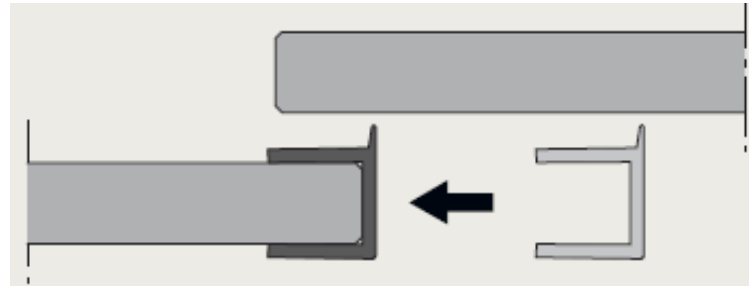

Vertical Gasket Seal:

For overlapping Doors

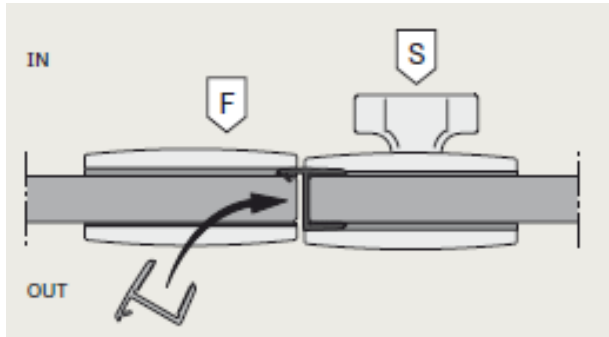

Door Seal

Optional Fixed Glass Panels

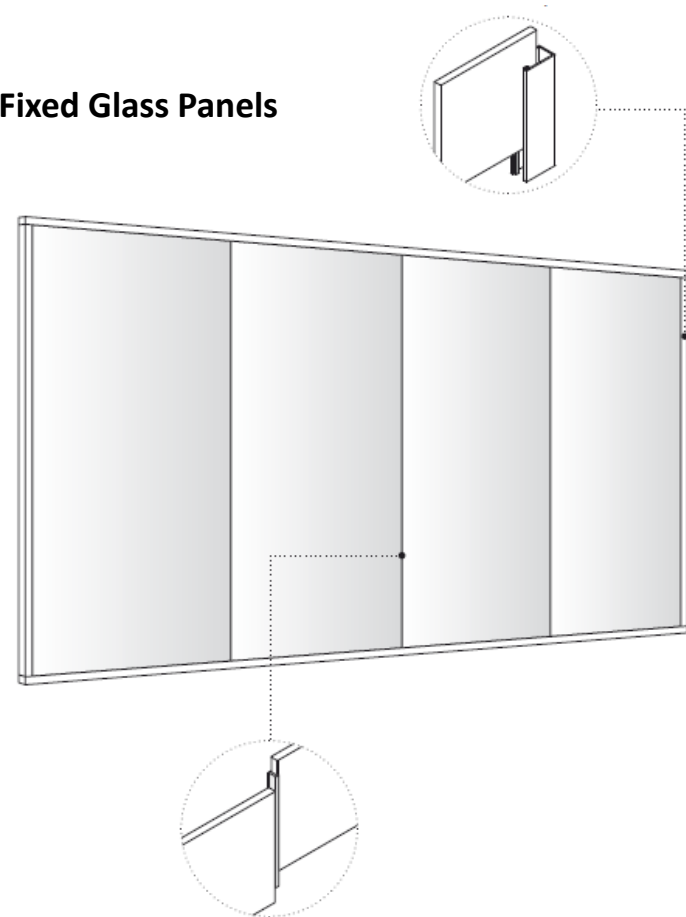

NOTES:

Note: Sunair® reserves the right to change engineering, specifications and prices without notice. Images and Illustrations in the catalog may vary from digital and printed manuals. Sunair® is not responsible for printed inaccuracies in this manual.

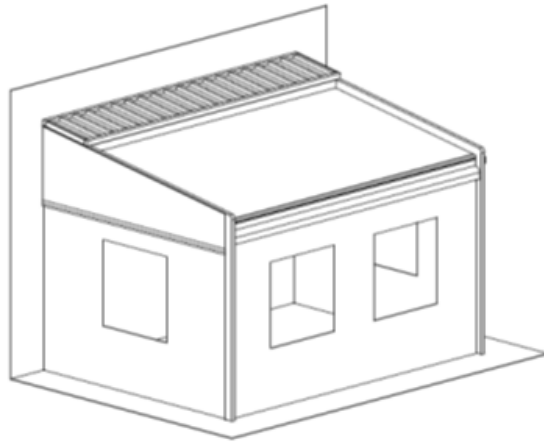

SUNPROOFING AMERICA!



MARYLAND LOCATION

Mailing: P.O. Box 1068

Shipping: 7785 Rt. 175

Jessup, MD 20794

Toll Free 800 - 548 - 0408

Phone: 410 - 799 - 1145

Fax: 410 - 799 - 5584

ARIZONA LOCATION

Mailing: Same as Jessup

Shipping: 3807 West Thomas Rd.

Phoenix, AZ 85017

Toll Free 877 - 272 - 3920

Phone: 602 - 272 - 3920

Fax: 602 - 272 - 3925

www.sunairawnings.com

info@sunairawnings.com